

3. Pickup Switch Upgrade Installation Instructions

Revised: January 16, 2023

Before you start, **read these instructions first** to understand what you need to do to install this product. These instructions are for our T2-Switch, T3-Switch, T3Plus-Switch, T4-Switch and T4Plus-Switch products.

Assumptions

These **Pickup Switch Upgrade™** products are designed to use only one Volume and one Tone control for all of your instrument's pickups. Your instrument will have 2, 3 or 4 magnetic pickup coils with two separate wires attached to each coil.

Note: Active or *Pizeo* pickups are not supported.

Tools Needed

You may need one or more of the following tools (not included with purchase) to install this product.

- Wire cutters / strippers, regular pliers
- Drill bits: 1/16" (1.59mm), 9/32" (7.14mm)
- Small Phillips & straight slot screwdriver (a 4-way screwdriver can be used as a deep-well socket to remove switch mounting nuts.
- Ohmmeter to measure electrical continuity
- Soldering iron (25/30 watt max.) with fine tip, rosin-core solder .022" dia.

Preamble

Before you start, completely **remove all strings** from your pickguard equipped instrument for easy access to its parts. The strings may be old and replacing them will make your instrument sound even more *brilliant* after you install this product.

This **Pickup Switch Upgrade™** installation will have you cutting existing wires on your instrument. You may need to make wire connections, increase the length of existing wires, and drill several holes in your pickguard, control plate or instrument body.

Because you will be making several changes to your instrument, you need to have a plan to install this **Pickup Switch Upgrade™** product.

See the *Figure 2 – Reference Drawings* on a later page of this document. Use a pencil to draw the original circuit of your instrument **before** you proceed. When you document where the wires (and the colors) were connected on your instrument, you will have a way to restore it to its original condition should it become necessary. Since there is a large variation of pickup switch wiring that spans 50 years, you will need to draw your own pickup switch used in your original circuit

Adding Extra Wire

If your pickup or output jack wires are too short to easily reach the specified connection of the green terminal strip (J1) on the **Pickup Switch Upgrade™** board, here is what to do. Measure out the needed length of the RED or BLACK wire in the included **PARTS BAG** to permit the wire to reach the applicable connection. A length of 3" (7.62cm) is budgeted for each pickup wire and output jack extension. Insert the unstripped end of each wire completely into the provided 2-wire UY2 yellow/clear connector.

Use pliers to squeeze the UY2 connector top button so it is flush with the body to create a permanent electrical connection. Verify electrical continuity between the two pickup wires using an ohmmeter (some coil resistance will be present). The 71B grey wire nuts are used to make a firm and insulated connection to the output jack wires, but let you easily disconnect and remove this product if needed.

Note: If either your pickup or output jack wires use a shielded/braided cable, you will need to solder black wire to the cable because the green terminal strip (J1) does not directly accept shielded cable.

Product Variants

This document contains installation instructions that are for our **Pickup Switch Upgrade™** product. We produce other products with their own installation instructions and are available on our website at:

www.AweSome-Guitars.com/docs

1. PICKUP SWITCH UPGRADE INSTALLATION INSTRUCTIONS

You are installing either a factory assembled *or* user-assembled KIT version of our Pickup Switch products. They are for any electric guitar, electric bass and other instruments with magnetic coil-wound pickups.

This switching system does not support active (battery-powered) pickups or piezoelectric pickups.

To accommodate a number of instrument pickup configurations, the following switch upgrades are available.

- **T2-Switch** – For two separate pickup coils. Uses three mini toggle switches giving you 6 pickup tones. Clearance dimensions: 1.00” wide x 1.75” long x 1.15” deep (2.54cm x 4.45cm x 2.92cm).
- **T2Plus-Switch** – Similar to the T2-Switch but with extra features. See document L2 for details. Clearance dimensions: 1.00” wide x 1.75” long x 1.15” deep (2.54cm x 4.45cm x 2.92cm).
- **T3-Switch** – For three separate pickup coils. Uses three mini toggle switches for 13 pickup tones. Clearance dimensions: 1.00” wide x 1.75” long x 1.15” deep (2.54cm x 4.45cm x 2.92cm).
- **T3Plus-Switch** – For three separate pickup coils. Uses six mini toggle switches for 35 pickup tones. Clearance dimensions: 0.94” wide, 3.05” long, 1.15” deep (2.38cm x 7.75cm x 2.92cm).
- **S3Plus-Switch** – Similar to T3Plus-Switch but has two rows of three mini toggles for 35 pickup tones. Clearance dimensions: 1.75" wide, 1.75" long, 1.15" deep (4.45cm x 4.45cm x 2.92cm).
- **T4-Switch** – For four separate pickup coils. Uses six mini toggle switches giving you 68 pickup tones. Clearance dimensions: 1.00” wide, 3.05” long, 1.15” deep (2.54cm x 7.75cm x 2.92cm).
- **T4Plus-Switch** – For four separate pickup coils. Uses six mini toggle switches. Designed to combine with our VT-3 Volume-Tone Control to give you 102 pickup tones. Clearance dimensions: 1.00” wide, 3.05” long, 1.15” deep (2.54cm x 7.75cm x 2.92cm). All Switch Hole Spacing: 1/2” (12.7mm) center-to-center; Mounting Diameter: 9.32” (7.14mm)

The assembled and KIT version includes a **PARTS BAG** with the following items.

- Paper drill hole template
- Adhesive labels to mark your pickup wires and output jack wires
- An equal length each of black, red insulated wire (to lengthen pickup and output jack wires if needed)
- Stainless steel switch finishing washers
- 2 or 4 yellow/clear connectors (UY2) to extend pickup wires and output jack wires if needed
- 2 grey wire nuts (71B) to connect output jack wires to revised volume/tone control assembly
- Optional colored switch covers; White for pickup coil switches, Black for parallel-series switches

Preparation

If applicable, remove your strings. As needed, remove your existing pickguard or control plate screws. Document your instrument’s existing wiring *before* you disconnect them (see Preamble on page 1).

Locate the hot and ground wires that come from your instrument’s output jack and disconnect them from the components to which they are attached. Keep the wires that are attached to the output jack as long as possible.

Cut each of the pickup wires from the original pickup switch, keeping these pickup wires as long as possible. To modify your existing pickguard or control plate, remove the attached components. This will make it easy to use it as either as a template to make a replacement part, or identify where to drill the switch mounting holes.

Installing the Pickup Switch Upgrade

If you are installing the **Pickup Switch Upgrade™** into an existing (or replacement) pickguard or control plate, or mounting the switch through the instrument body, you need to determine two things. First, confirm that there is adequate body cavity clearance for the switch product. You also need to identify the specific location to drill the switch mounting holes.

To determine if there is adequate perimeter clearance for the product, tape the supplied **Styrofoam block** to the back side of your pickguard or control plate at the proposed position of the switches and confirm that the circuit board outside dimensions will have clearance in the body routing underneath the pickguard or control plate at the proposed position. Confirm that your routed body cavity has the 1.15" (2.92cm) depth requirements.

If you are installing a **T2-Switch** (for 2-pickup coils) or **T3-Switch** (for 3-pickup coils), you should trim the paper **drill hole template** on the dotted lines. The T2-Switch product uses SW1, SW3 and SW5. The T3-Switch product uses SW1, SW2 and SW3.

Once you have found the location with the needed clearance, put the included paper **drill hole template** on the pickguard or control plate with the solid line on the bottom edge (where the switch designations are printed) facing towards the bottom of your instrument (closest to the ground when the instrument is strapped on). The drill hole template has outlines for all three switch types. It also has the specific locations for each of the holes: 3 holes for T2-Switch or T3-Switch, and 6 holes for both T3plus-Switch (3-pickup coil version) and T4-Switch (4-pickup coil version.)

Firmly tape all 4 edges of this **drill hole template** to the back of the pickguard or control plate. This identifies where the holes must be drilled to mount the T2-Switch or T3-Switch. Use a center punch to *dimple* each of the centers. This will help to prevent the drill bit from "walking" when you first start drilling and result in a more precisely-drilled hole position. Before drilling, use a piece of wood stock to serve as a backing to avoid rough holes. Use an electric drill and 1/16" (1.59mm) drill bit to drill "pilot" holes at the location marked with the "+" symbol. After drilling the pilot holes (either 3 or 6) follow through with the 9/32" (7.14mm) drill bit for each of the holes. The switch mounting shafts are designed for 1/4" (6.35mm) holes, but all of the switch mounting holes must be 9/32" diameter (slightly larger) to compensate for assembly variances.

Mount the product using the applicable image in **Figure 1** as a general guide for right-hand or left-hand use.

DO NOT REMOVE THE BACKING NUT from the switches to gain extra length if the switch threaded shaft is not long enough to be securely mounted. Doing so will likely cause the threaded shaft of the switch to be extracted from the switch body when tightening the mounting nuts. In addition, do not excessively tighten the backup nut against the switch body because this also can cause the threaded shaft of the switch to be extracted from the switch body when tightening the backup nuts. **This damage is NOT covered by our warranty.**

If you are mounting the switch product in an area with excessive thickness, it is advisable to either remove the excess thickness or cut it out and fabricate a plastic or metal cover plate to mount the switches.

Attach the switch upgrade product to the pickguard or control plate by inserting it through the previously drilled holes. The switch product will be in the orientation shown in **Figure 1** examples. Put the provided stainless steel finishing washers over each switch and screw on the tightening nuts.

Confirm that the pickguard or control plate with the attached board will lay completely within the routed body cavity with no interference by the wood body. If it doesn't lay down flush here is what to do.

Loosen (but do not remove) all switch mounting nuts so that the **Pickup Switch Upgrade™** board can be slightly "Shifted" to achieve the needed clearance. If that doesn't work then temporarily remove the switch product by removing all the switch mounting nuts. Use a rat-tail file to "extend" the holes, elongating them in the direction opposite of the interference area. This should give you the needed clearance. If not, you need to cut a small amount of wood from your body in the interference area to provide the needed clearance. This must be done before you can proceed.

Rewire the Volume control and Tone control as indicated in the **Figure 2** illustration presented later in this document. You can also get a **volume and tone control assembly** at our website. We offer two versions; one contains 2 separate controls (VT-2), the other kit is a "stacked" control (VT-2) for tight space constraints. Each version is assembled, and includes wiring instructions via download from our website.

Green Terminal Strip

Here is how to attach wires to the **green** terminal strip (J1) that is on the **Pickup Switch Upgrade™** product circuit board. Use a small screwdriver or writing pen tip and press down on the square *release button* located directly above the wire hole. Hold the button down and insert the stripped wire completely into the wire connection hole and then release the button. Lightly tug on the wire to confirm it is firmly gripped by the Terminal Strip. A legend is printed on the circuit board with the name of each terminal strip wire hole from left to right. Attach each wire to the correct terminal strip hole. In all instances, connect the **GND** and **VOL** wires from the Volume/Tone control circuit displayed in **Figure 2** to the wire connection holes on the terminal strip.

```
T2P-Switch (6-hole terminal strip): [GND] [VOL] [+]Coil-2[-] [+]Coil-1[-]
T2-Switch (6-hole terminal strip): [GND] [VOL] [+]Coil-2[-] [+]Coil-1[-]
T2Plus (10-hole terminal strip): [R3] [R2] [GND] [VOL] [+]Coil-2[-] [+]Coil-1[-] [B3] [B2]
T3-Switch (8-hole terminal strip): [GND] [VOL] [+]Coil-3[-] [+]Coil-2[-] [+]Coil-1[-]
T3Plus (8-hole terminal strip): [GND] [VOL] [+]Coil-3[-] [+]Coil-2[-] [+]Coil-1[-]
S3Plus (8-hole terminal strip): [GND] [VOL] [+]Coil-3[-] [+]Coil-2[-] [+]Coil-1[-]
T3PJ-Sw. (8-hole terminal strip): [GND] [VOL] [+]Coil-3[-] [+]Coil-2[-] [+]Coil-1[-]
T4-Switch (10-hole terminal strip): [GND] [VOL] [+]Coil-4[-] [+]Coil-3[-] [+]Coil-2[-] [+]Coil-1[-]
T4Plus-Switch (same as T4 plus additional 6-hole terminal strip): [R3] [R2] [B3] [B2] [N/A] [N/A]
```

Caution: Do not insert hard items in the wire holes because it will decrease reliable electrical connection.

Connecting Your Pickup Wires

There is no industry standard for pickup wire lead colors. More common color pairs are red/black, red/white, black/white and white/shield. You are advised to use consistency when connecting *your* pickup wire color pairs to the **[+]** and **[-]** pickup connections on the green terminal strip (J1).

Determine which wire color for each pickup coil will be attached to the applicable **[+]** and **[-]** green terminal strip connector on our product. If one of the pickup wire connections is a shielded lead, always connect the shield to a **BLACK [-]** wire to be inserted in the green terminal strip on our switching system.

Determine if there is enough wire length from each 2-wire pickup coil to *comfortably* reach the corresponding connectors on the green terminal strip on the **Pickup Switch Upgrade™** product. If not, refer to the "Adding Extra Wire" topic (page 1).

WARNING: If your pickups have a metal bottom AND if either pickup coil wire is grounded to this housing (use an ohmmeter to check each wire to body), make sure your instrument's body cavity is not lined with grounded metal shielding (includes shielding paint) and the pickup housing does not have a separate grounding wire. **Reason:** This will cause the pickup to "short" to ground when the pickup switch is put into the regular/reverse phase. To fix this, isolate the pickup housing from the body cavity shielding with soft foam.

Strip off 3/16" (4.76mm) insulation from the end of each pickup wire and also the output jack wires then twist the exposed wire strands so they are tightly bound. Insert the wires of each pickup pair into the correct location on the green terminal strip (J1) using the process described in the above "Terminal Strip" topic. Attach the wires using either of the following instructions.

Use the two gray wire nuts (71B) to connect the labeled wires to your **output jack**. The red wire goes to the hot lead (normally red) on the output jack and the black wire goes to the ground lead on the output jack.

Note: If you have a ground wire coming from the bridge (and maybe from body cavity shielding), connect them to ground lead on the output jack.

T2-Switch Connections

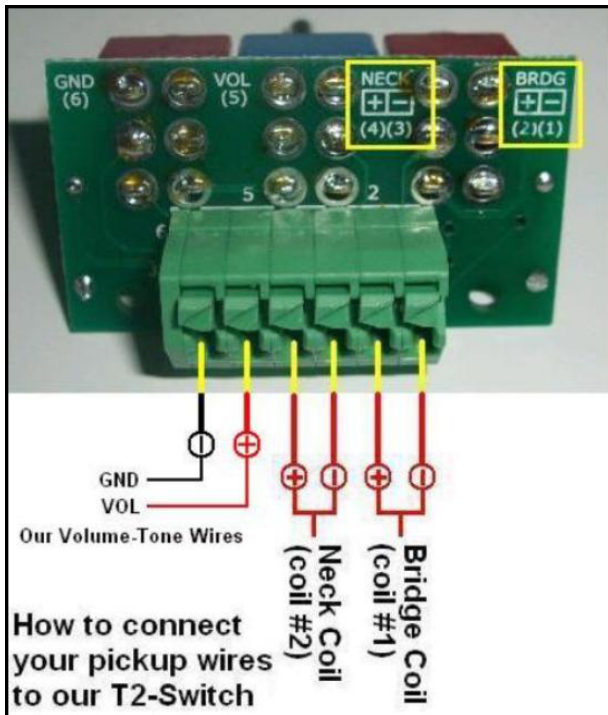

T3/T3Plus/S3Plus-Switch Connections

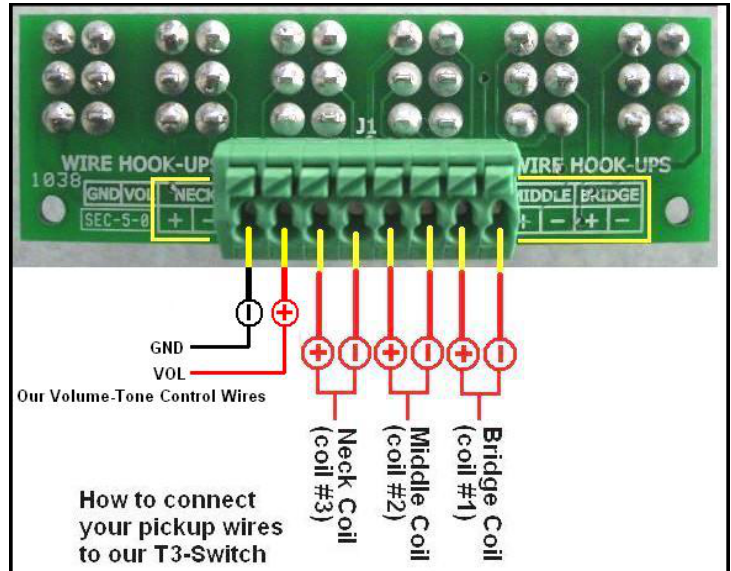

T4-Switch Connections

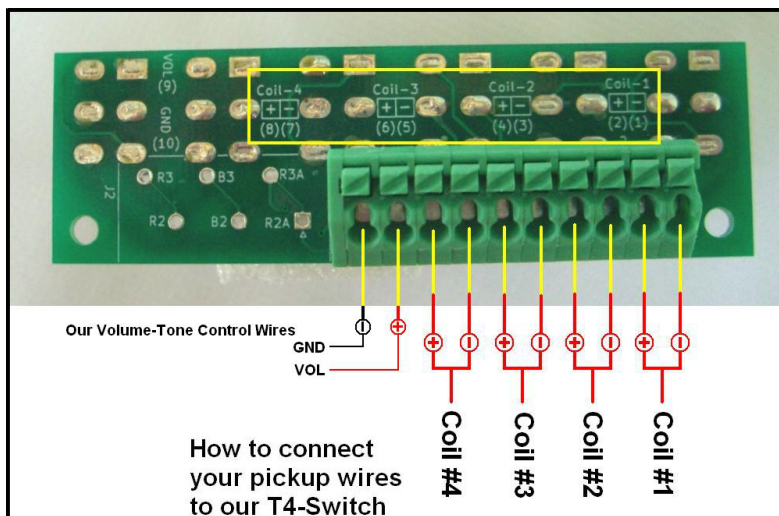

T4Plus-Switch Connections

This enhanced version is designed to permit connecting the four wires from the push-pull tone pot of our VT-3 Volume-Tone Control to the six position green solderless terminal strip. The wires are connected to a printed circuit board on the push-pull pot. The circuit board also contains the "R3/R2/B3/B2" designations for each wire.

Here is how to connect the VT-3 Volume-Tone Control push-pull pot wires to the T4Plus-Switch.

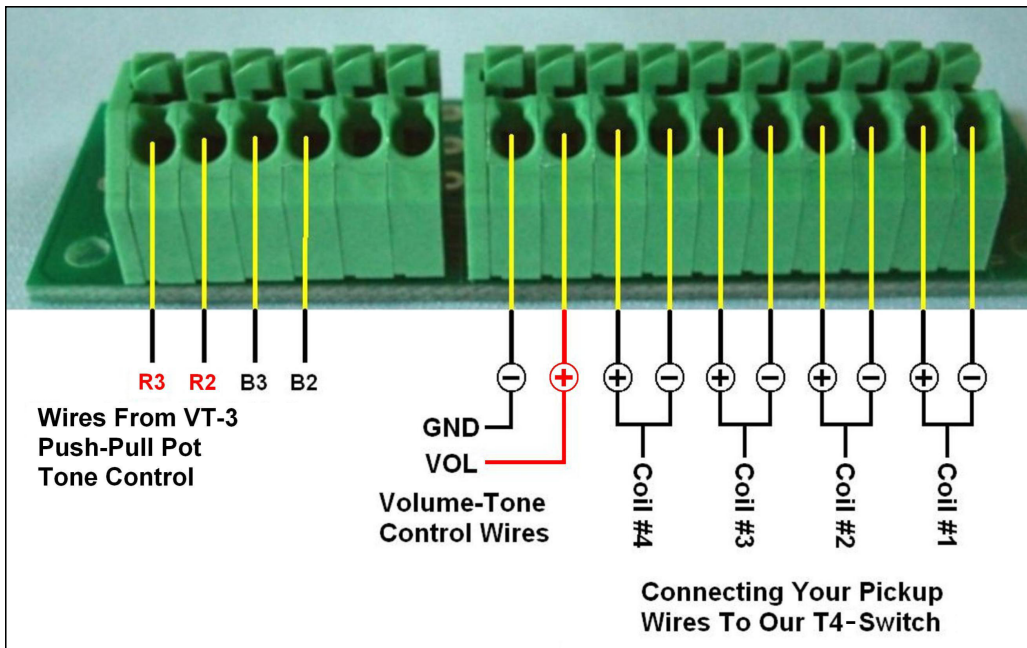

Connecting your two pickup coils to our T2-Switch or T2Plus-Switch product

Connect your **NECK** pickup coil wire pair to the [+]_{Coil-2} [-] connections on the green terminal strip
Connect your **BRIDGE** pickup coil wire pair to [+]_{Coil-1} [-] connections on the green terminal strip

T2-Switch Product Identification and Use Summary

Here is a summary of switch use for this product (see **Figure 1** for switch identification).

The *T2 Switch* document will help you “map” the pickup tones you get from the T2-Switch. It is available for download from our website’s Document Library.

SW1 and SW3 are ON-OFF-ON switches that turn on individual pickups in normal or reverse phase
SW5 is an ON-ON switch that changes the pickups from *Parallel* to *Series* connectivity

Switch Use:

SW1 turns on the **bridge** pickup, either in normal phase (down), or reverse phase (up).

SW3 turns on the **neck** pickup, either in normal phase (down), or reverse phase (up).

SW5 When this switch is **down**, the pickups will be in a *Parallel* circuit.

When this switch is **up** it puts the **bridge** and **neck** pickups in a *Series* circuit. Both pickups must be on, either in normal phase(down) or reverse phase (up).

Connecting your three pickup coils to our T3-Switch, T3Plus-Switch or S3Plus-Switch product

Connect your NECK pickup coil wire pair to the	[+]Coil-3[-]	connections on the green terminal strip
Connect your MIDDLE pickup coil wire pair to the	[+]Coil-2[-]	connections on the green terminal strip
Connect your BRIDGE pickup coil wire pair to the	[+]Coil-1[-]	connections on the green terminal strip

T3/T3Plus/S3Plus-Switch Product Identification and Use Summary

Here is a summary of switch use for this product (see **Figure 1** for switch identification).

The *T3Plus Switch* document will help you “map” the pickup tones you get from the T3-Switch and document #D will help you “map” the pickup tones you get from the T3Plus-Switch. These documents are available for download from our website’s Document Library.

SW1, SW2 and SW3 are ON-OFF-ON switches that turn on individual pickups in normal or reverse phase
SW4, SW5 and SW6 are ON-ON switches that change select pickups from *Parallel* to *Series* connectivity

Note: The T3-Switch only uses SW1, SW2 and SW3.

Switch Use:

SW1 turns on the **bridge** pickup, either in normal phase (down), or reverse phase (up).
SW2 turns on the **middle** pickup, either in normal phase (down), or reverse phase (up).
SW3 turns on the **neck** pickup, either in normal phase (down), or reverse phase (up).

*When all of the following switches are **down**, the pickups will be in a Parallel circuit.*

SW4 when this switch is **up** it puts the **bridge** and **middle** pickups in *Series*. Both pickups must be on.¹
SW5 when this switch is **up** it puts the **bridge** and **neck** pickups in *Series*. Both pickups must be on.¹
SW6 when this switch is **up** it puts the **neck** and **middle** pickups in *Series*. Both pickups must be on.¹
SW4+SW6 when these switches are **up**, all three pickups are in *Series*. All three pickups must be on. SW5 has no effect.

¹ The remaining *non-series* pickup may be either off -or- on (either in regular or reverse phase).

Connecting your four pickup coils to our T4-Switch product

Connect your **Neck North** pickup coil wire pair to the [+]Coil-4 [-] connections on the green terminal strip
Connect your **Neck South** pickup coil wire pair to the [+]Coil-3 [-] connections on the green terminal strip
Connect your **Bridge North** pickup coil wire pair to the [+]Coil-2 [-] connections on the green terminal strip
Connect your **Bridge South** pickup coil wire pair to the [+]Coil-1 [-] connections on the green terminal strip

T4-Switch Identification and Use Summary

Here is a summary of switch use for this product (see **Figure 1** for switch identification).

The *T4 Switch* document will help you “map” the pickup tones you get from the T4-Switch. It is available for download from our website’s Document Library.

S1N, S2N, S1B and S2B are ON-OFF-ON switches that turn on individual pickups in normal or reverse phase
S5N and S5B are ON-ON switches that change select pickup coils from *Parallel* to *Series* connectivity

Switch Use:

- SW1 turns on **Bridge South** pickup coil, either in normal phase (down), or reverse phase (up).
SW2 turns on **Bridge North** pickup coil, either in normal phase (down), or reverse phase (up).
S5B When this switch is **down**, both bridge pickup coils will be in a *Parallel* circuit.
When this switch is **up** it puts **Bridge South** and **Bridge North** pickup coils in a *Series* circuit. Both pickup coils must be on, either in normal phase (down) or reverse phase (up).

SW3 turns on **Neck South** pickup coil, either in normal phase (down), or reverse phase (up).
SW4 turns on **Neck North** pickup coil, either in normal phase (down), or reverse phase (up).
S5N When this switch is **down**, both neck pickup coils will be in a *Parallel* circuit.
When this switch is **up** it puts **Neck South** and **Neck North** pickup coils in a *Series* circuit. Both pickup coils must be on, either in normal phase (down) or reverse phase (up).

T4Plus-Switch Information

The T4Plus-Switch works the same as the T4-Switch. When combined with our VT-3 Volume-Tone Control, you get 50 percent more pickup tones. Refer to our website Document Library (documents #F and #G) for additional information about using this product.

Validating

Connect your instrument to an amplified source with the volume set to low. Turn the switches on and off as described in “*Switch Identification and Use Summary*” topic while gently tapping the magnet of the pickup coil that should be “on” with a small screwdriver to confirm pickup response. Also confirm the correct operation of the Volume and Tone controls.

If you receive the stated results, install the pickguard screws. Next, install a new set of strings. Welcome to the *Grand Canyon Wide* range of AweSome pickup tones.

Figure 1 – Sample Pickup Switch Upgrade Mounts and Switch Identification

Here are some examples to guide you in installing our switch products and the switch designations.

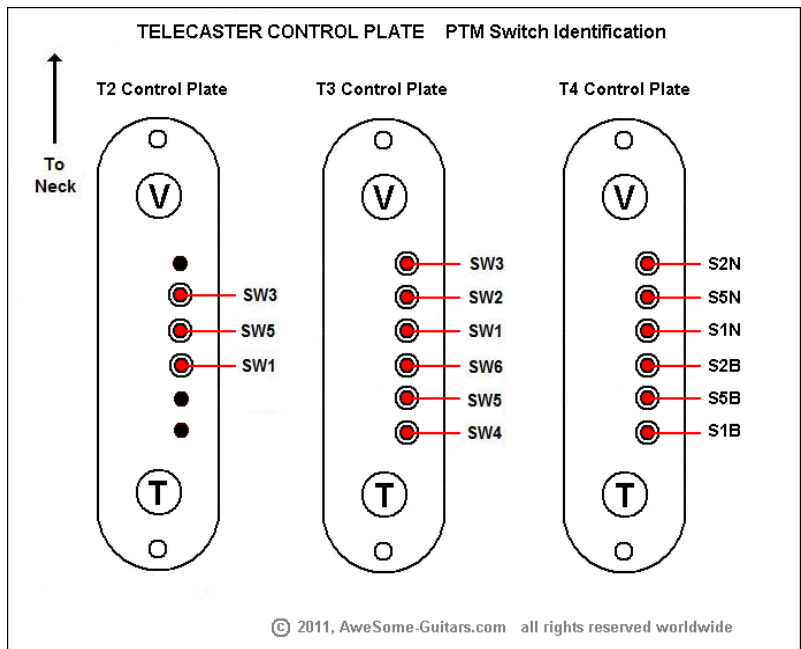
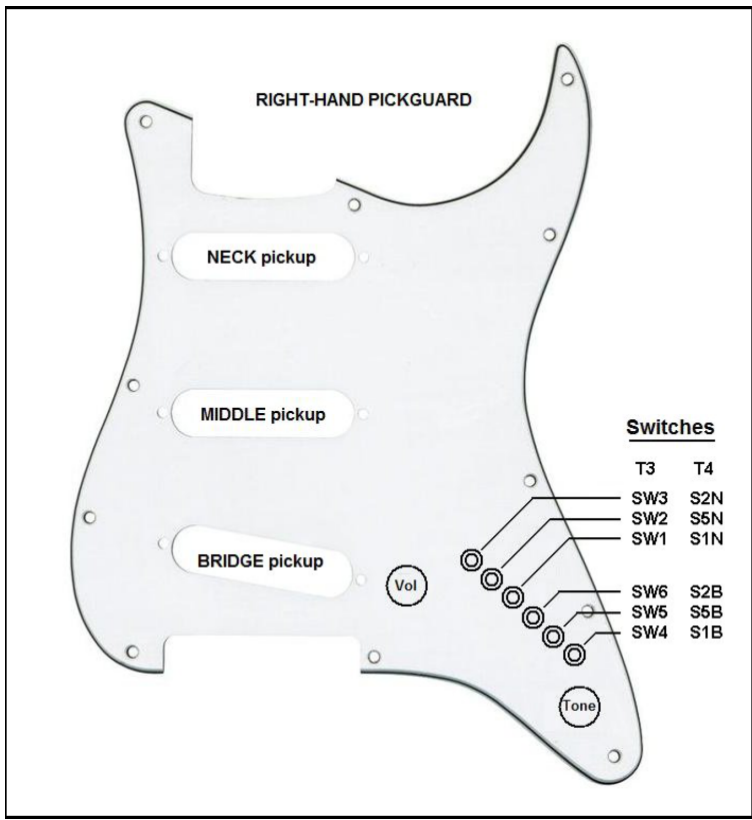

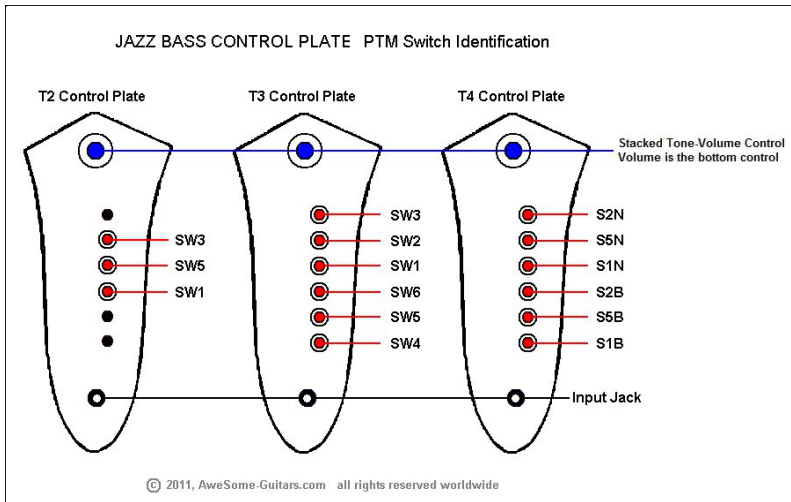
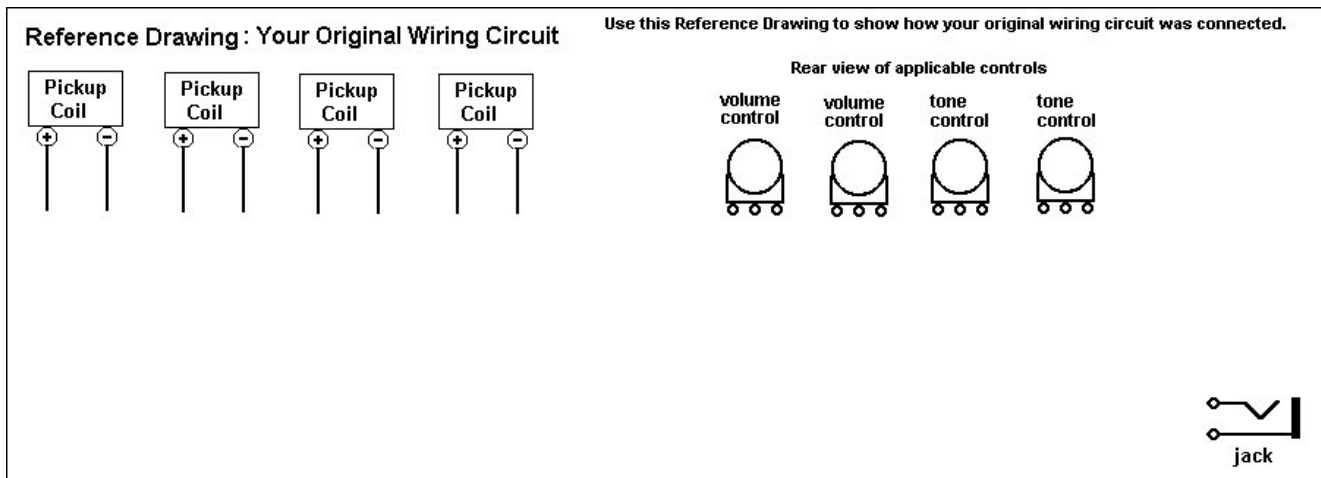

Figure 2 – Reference Drawings

Use the following drawing to document your instrument’s original wiring. Using a pencil, identify wire colors where needed. Because of the numerous variations that span 50+ years, you must draw your own pickup switch.

Use the following drawing to identify how to connect this **Pickup Switch Upgrade™** product. It identifies how to rewire your Volume and Tone controls. This drawing shows you how to connect your rewired Volume and Tone controls. We also offer VT-1 or VT-2 products that are available in Right-Hand audio taper.



Suggested Volume-Tone Wiring for use with our Pickup Switch Upgrade™ products

terminal strip connection guide

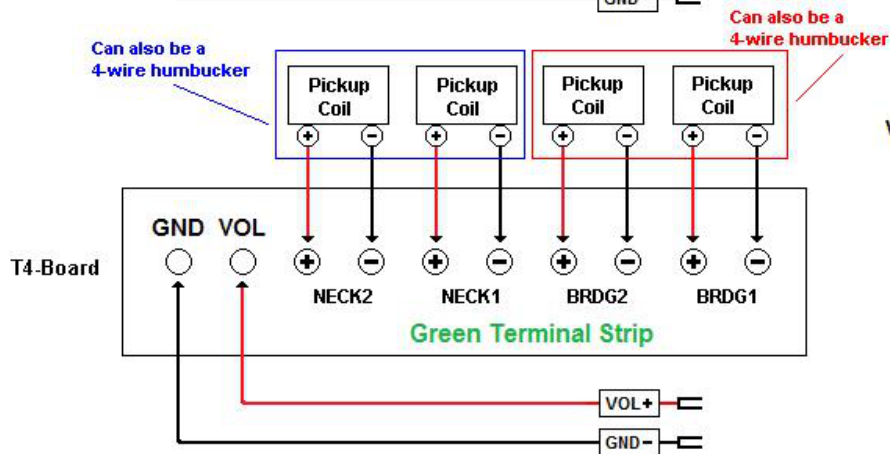
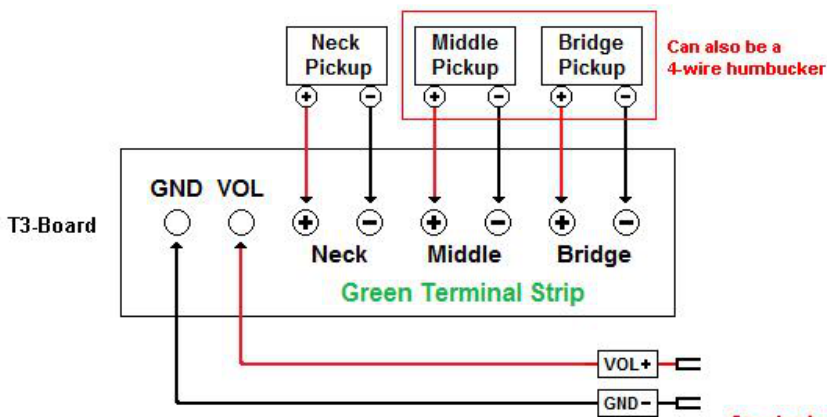
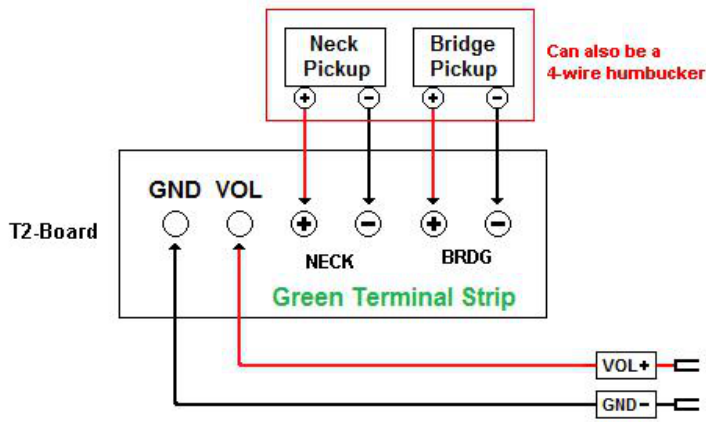

VT-2 (Volume/Tone Control) RIGHT-HAND WIRING

⊥ areas marked with this symbol MUST be electrically connected

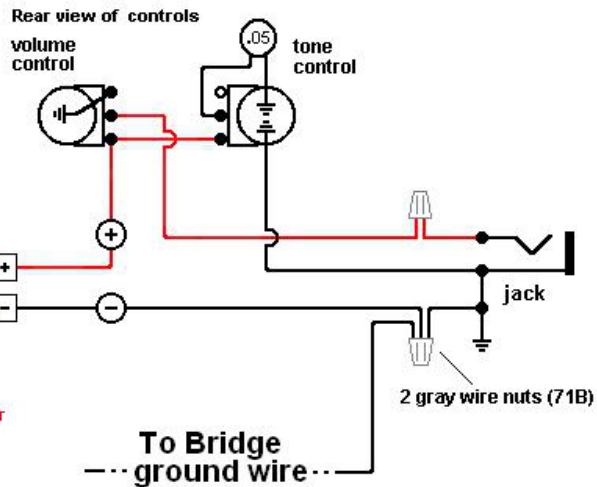

VOLUME Knob on Bottom

VT-1 (Stacked Volume/Tone Control) RIGHT-HAND WIRING

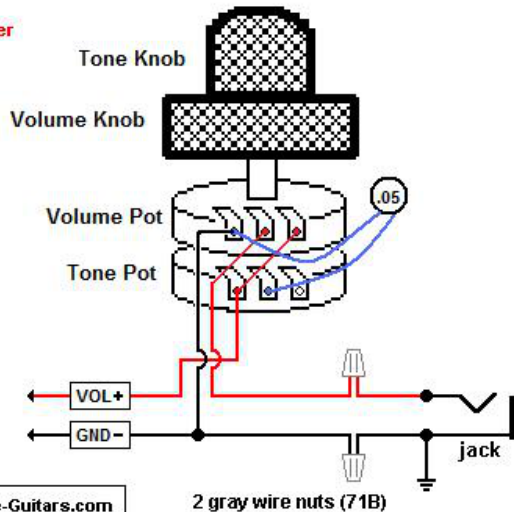

(C) 2011 AweSome Musical Instruments, All rights reserved worldwide www.AweSome-Guitars.com