

Before you start, **read these instructions first** to understand what you need to do to install this product.

Assumptions

This upgrade product is designed to use only one Volume and one Tone control for all of your instrument's pickups. It is designed to control 2 magnetic pickup coils. **Note:** EMG (active) or *Pizeo* pickups cannot be used with this product.

Tools Needed

You may need one or more of the following tools (not included with purchase) to install this upgrade product.

- Wire cutters / Wire strippers
- Regular pliers
- Small Phillips & straight slot screwdriver (a 4-way screwdriver can be used as a deep-well socket to remove switch mounting nuts.
- Ohmmeter to measure electrical continuity
- Optional: Soldering iron (25/30 watt max.) with fine tip, rosin-core solder .022" dia.

Preamble

This installation will have you cutting existing wires on your instrument. You may need to make wire connections, increase the length of existing wires, and drill holes in your instrument body.

Because you will be making several changes to your instrument, you need to have a plan to install upgrade product.

See the *Reference Drawing* on a later page of this document. Use a pencil to draw the original circuit of your instrument before you proceed. When you record

where the wires (and colors) were removed from your instrument, you have a way to restore it to its original condition should it become necessary. Since there is a large variation of pickup switch wiring that spans 50 years, you will need to draw your own pickup switch used in your original circuit

Adding Extra Wire

If your pickup or input wires are too short to easily reach the specified connection of the green terminal strip on the **Pickup Switch Upgrade™** circuit board, here is what to do. Measure out the needed length of the RED or BLACK wire in the included **PARTS BAG** to permit the wire to reach the applicable connection. A length of 3" (7.62cm) is budgeted for each wire extension. Insert the unstripped end of each wire into the 2-wire UY2 yellow/clear or UR2 red/clear connector and clamp down using regular pliers.

Use pliers to squeeze the UY2 connector top button so it is flush with the body to create a permanent electrical connection. Verify electrical continuity between the two pickup wires using an ohmmeter (some coil resistance will be present). The 71B grey wire nut is used to make the needed firm and insulated connection between your bridge ground wire and the input jack ground wire, but let you easily remove the control plate if needed.

Note: If either your pickup or input wires use a shielded/braided cable, you will need to solder black wire to the cable because the green terminal strip (J1) does not directly accept shielded cable.

Special Note: For easy identification, switches now have colored covers for easy identification: White pickup coil switches, Black parallel-series switches.

JAZZ BASS CONTROL PLATE

You have received an assembled and tested enhanced control plate designed to install into a standard American Jazz Bass guitar. It contains one of our T2-Switch product, one stacked tone and volume control with matching knobs. No soldering is needed to install this product. You will use your own pickups. The following items are included and used for installation.

- An equal length each of black and red insulated wire (to lengthen pickup and input jack wire if needed)
- 2 or 4 yellow/clear connectors (UY2) or red/clear connectors (UR2) to make pickup wire extension connections if needed

Preparation

If needed, remove your strings. Remove your existing control plate attaching screws. Document your existing wiring (see *Preamble* on page 1) *before* you start.

Cut the pickup wires from the pickup switch so all wires are of maximum length.

Remove your original control plate. Stow input jack wires and pickup wires within the body cavity.

Confirm the Jazz Bass upgrade will lay completely flat and within the routed body cavity with no interference by the wood body. If the product doesn't lay down flush on your instrument, identify and remove the necessary amount of wood from your body in the interference area to provide the needed clearance. This must be done before you can proceed.

Terminal Strip

Here is how to attach wires to the **green** terminal strip (J1) that is on the upgrade circuit board. Use a small screwdriver or writing pen tip and press down on the square *release button* located directly above the wire hole. Hold the button down and insert the stripped wire completely into the wire connection hole and then release the button. Lightly tug on the wire to confirm it is firmly gripped by the Terminal Strip. A legend is printed on the circuit board with the name of each terminal strip wire hole from left to right. Attach each wire to the correct terminal strip hole. In all instances, connect the **GND** and **VOL** wires from the Volume/Tone control circuit displayed in **Figure 2** to the wire connection holes on the terminal strip.

T2-Switch (6-hole terminal strip): [GND] [VOL] [+]Coil-2[-] [+]Coil-1[-]
T3-Switch (8-hole terminal strip): [GND] [VOL] [+]Coil-3[-] [+]Coil-2[-] [+]Coil-1[-]
T4-Switch (10-hole terminal strip): [GND] [VOL] [+]Coil-4[-] [+]Coil-3[-] [+]Coil-2[-] [+]Coil-1[-]

Caution: Do not insert hard items in the wire holes because it will decrease reliable electrical connection.

Connecting Your Wires

There is no industry standard for pickup wire lead colors. More common color pairs are red/black, red/white, black/white and white/shield. You are advised to use consistency when connecting *your* pickup wire color pairs to the [+] and [-] pickup connections on the green terminal strip (J1).

Determine which wire color for each pickup coil will be attached to the applicable [+] and [-] green terminal strip connector on our Jazz Bass upgrade. If one of the pickup wire connections is a shielded lead, always connect the shield to a BLACK [-] wire to be inserted in the green terminal strip on our switching system.

Determine if there is enough wire length from each pickup coil to *comfortably* reach the corresponding connectors on the green terminal strip on the **Pickup Switch Upgrade™** circuit board. If not, refer to the “*Adding Extra Wire*” topic (page 1).

WARNING: If your pickups have a metal bottom and if either pickup coil wire is grounded to this housing (use an ohmmeter to check each wire to body), make sure your instrument’s body cavity is not lined with grounded metal shielding and the pickup housing does not have a separate grounding wire. **Reason:** This will cause the pickup to “short” to ground when the pickup switch is put into the regular/reverse phase. To fix this, isolate the pickup housing from the body cavity shielding with soft foam.

Strip off 3/16” (4.76mm) insulation from the end of each pickup wire and also the input jack wires then twist the exposed wire strands so they are tightly bound. Insert the wires of each pickup pair into the correct location on the green terminal strip (J1) using the process described in the above “*Terminal Strip*” topic. Attach the wires using either of the following instructions.

For side jack instruments, use the two gray wire nuts (71B) to connect the wires labeled “Output Jack” to the wires on your **output jack**. The red wire goes to the hot lead (normally red) on the input jack and the black wire goes to the ground lead on the input jack.

Note: If you have a ground wire coming from the bridge (and maybe from body cavity shielding), connect them to ground lead on the input jack using the provided grey wire nut.

Connecting your pickups to our T2-Switch

Connect your **NECK** pickup coil to [+]Coil-2[-] connections on the green terminal strip
Connect your **BRIDGE** pickup coil to [+]Coil-1[-] connections on the green terminal strip

T2-Switch Product Identification and Use Summary

Here is a summary of switch use for this product (see **Figure 1** for switch identification).

The *T2-Switch* document will help you “map” the pickup tones you get from the T2-Switch. It is available for download from our website’s Document Library.

SW1 and SW3 are ON-OFF-ON switches that turn on individual pickups in normal or reverse phase
SW5 is an ON-ON switch that changes the pickups from *Parallel* to *Series* connectivity

Special Note: For easy identification, switches now have colored covers: White for pickup coil switches, Black for parallel-series switches.

Switch Use:

SW1 turns on the **bridge** pickup, either in normal phase (down), or reverse phase (up).

SW3 turns on the **neck** pickup, either in normal phase (down), or reverse phase (up).

SW5 When this switch is **down**, the pickups will be in a *Parallel* circuit.

When this switch is **up** it puts the **bridge** and **neck** pickups in a *Series* circuit. Both pickups must be on, either in normal phase(down) or reverse phase (up).

Connecting your pickups to our T3Plus-Switch

Connect your NECK pickup coil to	[+]Coil-3[-]	connections on the green terminal strip
Connect your MIDDLE pickup coil to	[+]Coil-2[-]	connections on the green terminal strip
Connect your BRIDGE pickup coil to	[+]Coil-1[-]	connections on the green terminal strip

T3Plus-Switch Product Identification and Use Summary

Here is a summary of switch use for this product (see **Figure 1** for switch identification).

The *T3Plus-Switch* document will help you “map” the pickup tones you get from the T3Plus-Switch. It is available for download from our website’s Document Library.

SW1, SW2 and SW3 are ON-OFF-ON switches that turn on individual pickups in normal or reverse phase
SW4, SW5 and SW6 are ON-ON switches that change select pickups from *Parallel* to *Series* connectivity

Special Note: For easy identification, switches now have colored covers: White for pickup coil switches, Black for parallel-series switches.

Switch Use:

SW1 turns on the **bridge** pickup, either in normal phase (down), or reverse phase (up).
SW2 turns on the **middle** pickup, either in normal phase (down), or reverse phase (up).
SW3 turns on the **neck** pickup, either in normal phase (down), or reverse phase (up).

*When all of the following switches are **down**, the pickups will be in a Parallel circuit.*

SW4 when this switch is **up** it puts the **bridge** and **middle** pickups in *Series*. Both pickups must be on.¹
SW5 when this switch is **up** it puts the **bridge** and **neck** pickups in *Series*. Both pickups must be on.¹
SW6 when this switch is **up** it puts the **neck** and **middle** pickups in *Series*. Both pickups must be on.¹
SW4+SW6 when switches are **up**, all three pickups are in *Series*. All pickups must be on. SW5 has no effect.

¹ The remaining *non-series* pickup may be either off -or- on (either in regular or reverse phase).

Connecting your pickups to our T4-Switch

If you are using two 4-wire humbucker pickups:

Connect your NECK1 pickup coil wire pair to the	[+]Coil-4 [-]	connections on the green terminal strip
Connect your NECK2 pickup coil wire pair to the	[+]Coil-3 [-]	connections on the green terminal strip
Connect your BRIDGE1 pickup coil wire pair to the	[+]Coil-2 [-]	connections on the green terminal strip
Connect your BRIDGE2 pickup coil wire pair to the	[+]Coil-1 [-]	connections on the green terminal strip

If you are using two single-coil pickups and one 4-wire humbucker pickup:

Connect your NECK pickup coil wire pair to the	[+]Coil-4 [-]	connections on the green terminal strip
Connect your MIDDLE pickup coil wire pair to the	[+]Coil-3 [-]	connections on the green terminal strip
Connect your BRIDGE1 pickup coil wire pair to the	[+]Coil-2 [-]	connections on the green terminal strip ¹
Connect your BRIDGE2 pickup coil wire pair to the	[+]Coil-1 [-]	connections on the green terminal strip ¹

¹ Assumes that the bridge pickup position contains a stacked 4-wire humbucker pickup

T4-Switch Product Identification and Use Summary

Here is a summary of switch use for this product (see **Figure 1** for switch identification).

The *T4-Switch* document will help you “map” the pickup tones you get from the T4-Switch. It is available for download from our website’s Document Library.

S1N, S2N, S1B and S2B are ON-OFF-ON switches that turn on individual pickups in normal or reverse phase
S5N and S5B are ON-ON switches that change select pickup coils from *parallel* to *series* connectivity

Special Note: For easy identification, switches now have colored covers: White for pickup coil switches, Black for parallel-series switches.

Switch Use:

S1B turns on **BRIDGE1** pickup coil, either in normal phase (down), or reverse phase (up).
S2B turns on **BRIDGE2** pickup coil, either in normal phase (down), or reverse phase (up).
S5B When this switch is **down**, both bridge pickup coils will be in a *Parallel* circuit.
When this switch is **up** it puts **BRIDGE1** and **BRIDGE2** pickup coils in a *Series* circuit. Both pickup coils **must** be on, either in normal phase (down) or reverse phase (up).

S1N turns on **NECK1** pickup coil, either in normal phase (down), or reverse phase (up).
S2N turns on **NECK2** pickup coil, either in normal phase (down), or reverse phase (up).
S5N When this switch is **down**, both neck pickup coils will be in a *Parallel* circuit.
When this switch is **up** it puts **NECK1** and **NECK2** pickup coils in a *Series* circuit. Both pickup coils **must** be on, either in normal phase (down) or reverse phase (up).

Validating

Connect your instrument to an amplified source with the volume set to low. Turn the switches on and off as described in “*Switch Identification and Use Summary*” topic while gently tapping the magnet of the pickup coil that should be “on” with a small screwdriver to confirm pickup response. Also confirm the correct operation of the Volume and Tone controls.

Our VT-1 stacked pot control is only available as right-hand audio taper item. Because only the larger diameter knob of the VT-1 control supports reliable “pinky” swells, the suggested wiring is presented for Volume swells. If you receive the stated results, install the pickguard screws. Next, install a new set of strings. Welcome to the *Grand Canyon Wide* range of AweSome pickup tones. This product will produce a wide spectrum of unique pickup sounds that you have NEVER even heard before.

Figure 1 – Sample Pickup Switch Upgrade Mounts and Switch Identification

Here are some examples to guide you in installing our Jazz Bass upgrades and the switch designations.

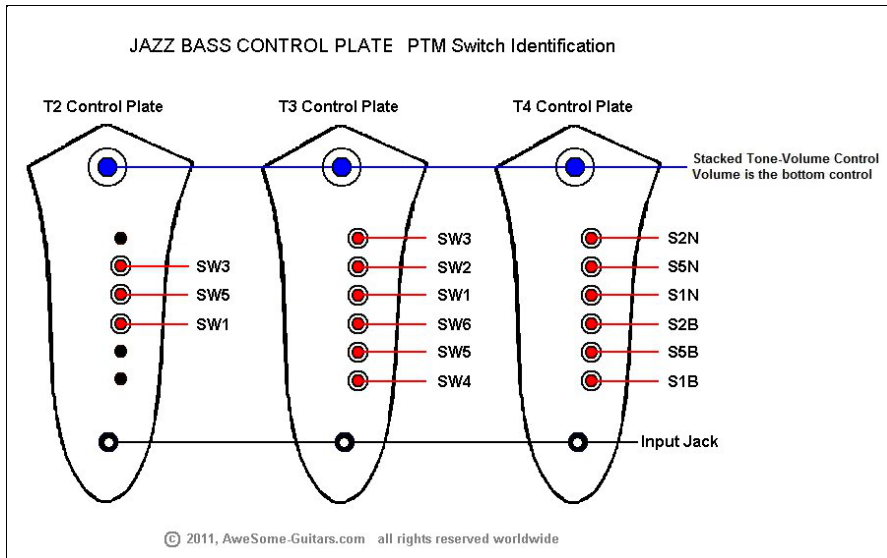
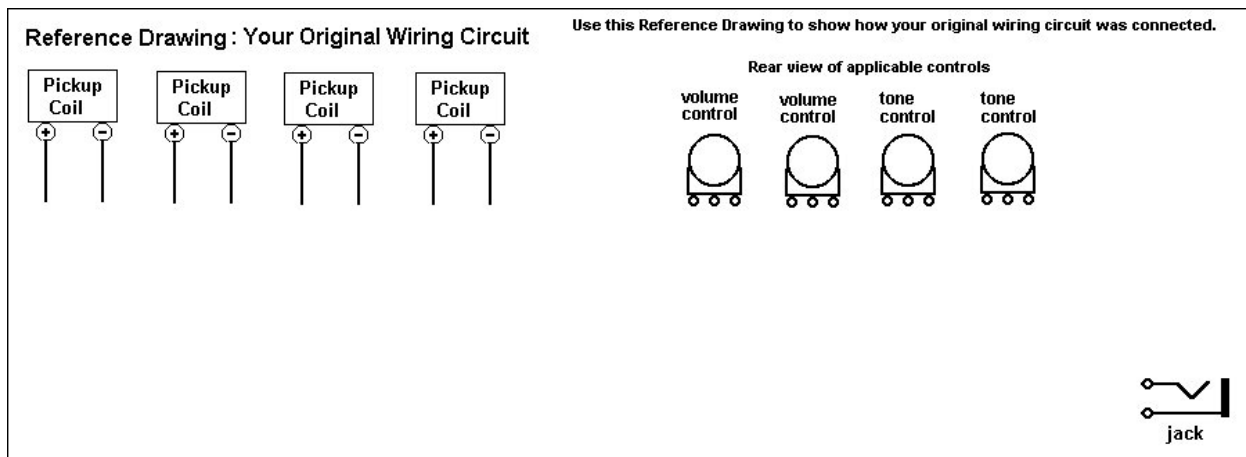

Figure 2 – Reference Drawings

Use the following drawing to document your instrument's original wiring. Using a pencil, identify wire colors where needed. Because of the numerous variations that span 50+ years, you must draw your own pickup switch.



Use the following drawing to identify how to connect this **Pickup Switch Upgrade™** product. It identifies how to wire your Volume and Tone controls using our VT-1 products. Our VT-1 products are only available in Right-Hand audio taper.

Suggested Volume-Tone Wiring for use with our Pickup Switch Upgrade™ products

VOLUME Knob on Bottom

VT-1 (Stacked Volume/Tone Control)
RIGHT-HAND WIRING

terminal strip connection guide

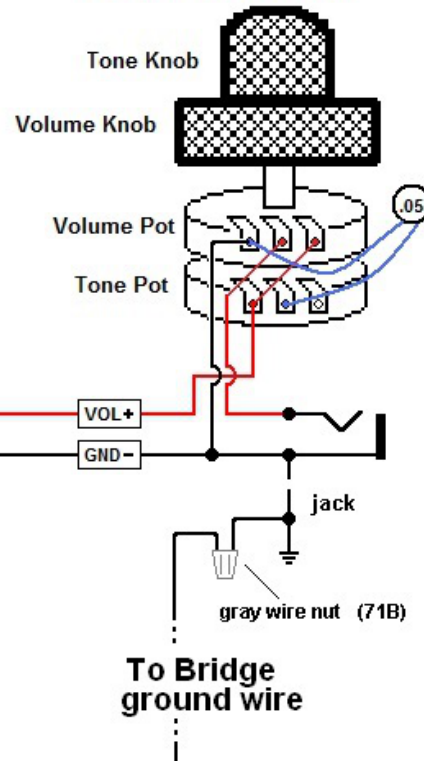
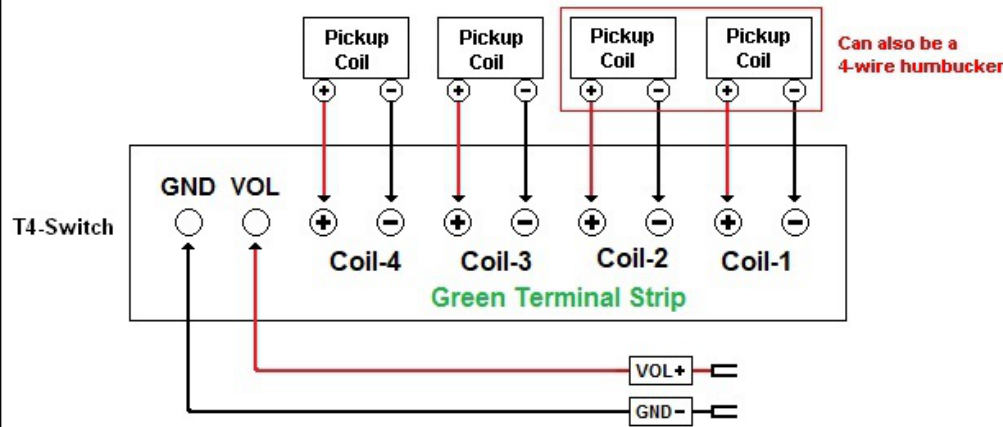
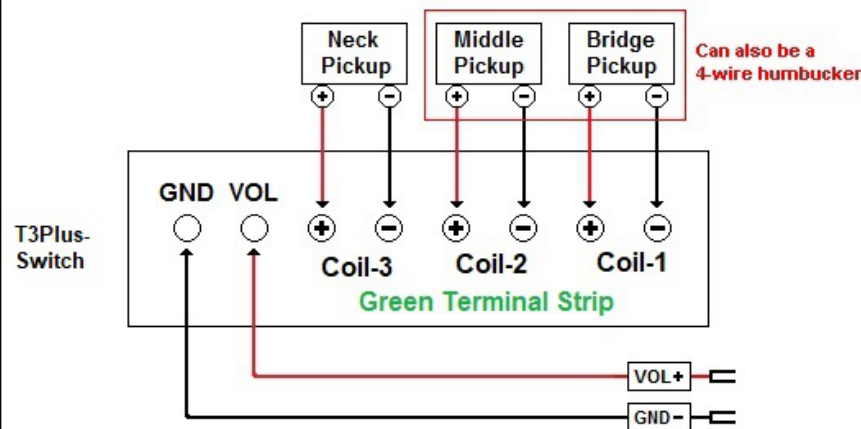
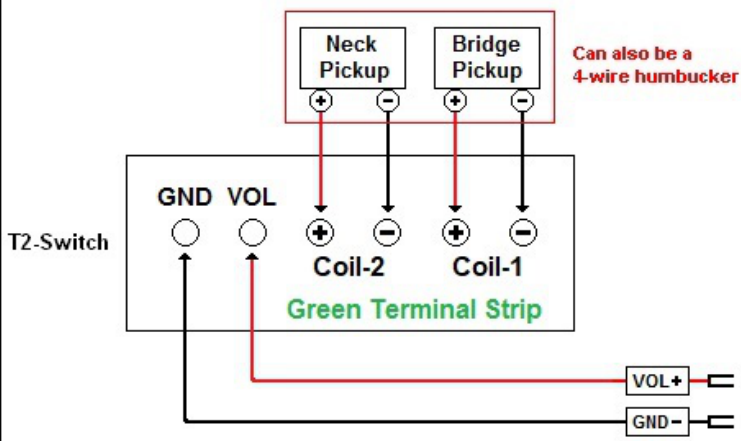

(C) 2011 AweSome Musical Instruments, All rights reserved worldwide www.AweSome-Guitars.com