

Before you start, **read these instructions first** to understand what you need to do to install this product. These installation instructions are for our **T2P-Switch** product designed specifically for a standard American Precision Bass instrument that produces one pickup tone. This simple upgrade will give you four pickup tones.

Assumptions

This **Pickup Switch Upgrade™** product is designed to use one Volume and one Tone potentiometer to control all of your instrument's pickups. Your instrument will have 2 magnetic pickup coils with two separate wires attached to each pickup coil.

Note: Active or *Pizeo* pickups are not supported.

Tools Needed

You may need one or more of the following tools (not included with purchase) to install this product.

- Wire cutters / strippers, regular pliers
- Drill bits: 1/16" (1.6mm), 5/16" (7.9mm)
- Small Phillips & straight slot screwdriver (a 4-way screwdriver can be used as a deep-well socket to tighten switch mounting nuts)
- Ohmmeter to measure electrical continuity
- Soldering iron (25/30 watt max.) with fine tip, rosin-core solder .022" diameter

Preamble

This **Pickup Switch Upgrade™** installation will have you cutting existing wires on your instrument. You will also make wire connections to increase the length of existing wires, and drill holes in your pickguard, control plate or instrument body.

Because you will make changes to your instrument, you need to have a plan to install this **Pickup Switch Upgrade™** product.

See the *Figure 1 – Reference Drawings* on a later page of this document. Use a pencil to draw the original circuit of your instrument before you proceed. When you document where the wires on your instrument (and the colors of these wires) were connected, you will have a way to restore it to its original condition should it become necessary. Since there is a large variation of wiring schematics that spans 50 years, you need to draw the circuit that is specific to your own instrument.

Adding Extra Wire

After cutting the pickup wires (described later), the pickup wires will be too short to reach the specified connection of the Green terminal strip (J1) on the **Pickup Switch Upgrade™** product. You must cut the RED and BLACK wires that are in the included **PARTS BAG** into 6" (15.2cm) lengths and electrically connect them together to permit the wire to reach the Green terminal strip connections. A length of 6" (15.2cm) is budgeted for each pickup wire. Insert the unstripped end of each wire completely into the provided 2-wire UY2 yellow/clear connector.

Use pliers to firmly squeeze the UY2 connector top button so it is flush with the body to create a permanent electrical connection. After extending the wires, verify electrical continuity between the two pickup wires using an ohmmeter (some coil resistance will be present).

Note: If either of your pickup wires uses a shielded / braided cable, you will need to solder the black wire to the shield cable because the green terminal strip (J1) does not directly accept shielded cable.

Product Variants

This document contains installation instructions that are for our T2P **Pickup Switch Upgrade™** product. Other products that we produce contain their own installation instructions and are available on our website's **Document Library** at:

www.AweSome-Guitars.com

1. P-BASS T2P-SWITCH INSTALLATION INSTRUCTIONS

You are installing either a factory assembled and tested T2P-Switch *or* user-assembled KIT version of our T2P-Switch. This item is part of our growing family of *high performance* **Pickup Switch Upgrade™** products. This upgrade is for any American Precision Bass or similar clone instrument with two magnetic coil-wound pickups.

The assembled board and KIT version includes a **PARTS BAG** with the following items used for installation.

- Wire decals, 2 stainless switch finishing washers
- An 18” (30.5cm) length each of Black and Red insulated wire to lengthen pickup wires
- Styrofoam block, 1.75” x 0.625” (4.44cm x 1.59cm)
- 4 yellow/clear connectors (UY2) to extend pickup wires
- 1 grey wire nut (71B) to reconnect the bridge ground wire

Special Note: Although you *will get four unique pickup tones* from your stock instrument when you use this product, your result will be more dramatic if you use two pickup coils that are dissimilar. Diversity in pickups with different coil impedance or magnet type (or both) will give you a greater variety of pickup tones.

1. Preparation

If applicable, remove your strings for easy access to all components. Remove all pickguard screws and carefully remove the pickguard. While viewing the back of the pickguard, document the existing wiring *before* anything is disconnected (see *Preamble* on page 1 and *Figure 1 – Reference Drawing* later in this document). Use tape to mark the pickups as “Neck” and “Bridge”. Remove the pickup screws then remove the pickups. If applicable, remove the screw that attaches a ground wire to the body cavity. Unsolder or disconnect the bridge ground wire near the body cavity. Everything is now accessible and completely detached from the instrument body.

Take note of the stock wiring of your Precision Bass instrument. See *Figure 2 – Typical Stock Wiring* later in this document for a *typical* stock wiring example.

2. Making Wiring Revisions

Refer to *Figure 3 – Upgrade Wiring Revisions* while completing these wire revision steps.

1. As described in item “A” of Figure 3, cut the pickup jumper wire that connects one pickup to the other so there is an equal amount of wire coming from each pickup. Do not strip either of the wire ends that are connected to the pickups.
2. As described in item “B” of Figure 3, cut each pickup wire 3” (7.62cm) from each pickup. Do not strip either of the wire ends that are connected to the pickup.
3. As described in item “C” of Figure 3, strip 3/8” (9.5mm) insulation from the end of the wire that is connected to the volume control terminal and twist wire bundle so it is tightly bound. Optionally, use a soldering iron to lightly *tin* (i.e., flow solder in the wire bundle) the end of the wire so it doesn’t unravel.
4. As described in item “D” of Figure 3, strip 3/8” (9.5mm) insulation from the end of the wire that is connected to the volume control metal housing (ground connection) and twist wire bundle so it is tightly bound. Optionally, use a soldering iron to lightly *tin* the end of the wire so it doesn’t unravel.

5. Do this for both pickup wires (the pickup jumper wire) that you previously cut as described in item “A”. Take the cut end of each pickup wire and completely insert it into one of the two holes in a yellow/clear connector (UY2). Insert a 6” Black wire into the connector. With both wires completely inserted into the connector, use a pair of pliers to firmly press the yellow button of the UY2 connector so it is flush with the clear body. Strip 3/8” (9.5mm) insulation from the end of the Black wire and twist wire bundle so it is tightly bound. Optionally, use a soldering iron to lightly *tin* the end of the wire so it doesn’t unravel.
6. Do this for both pickup wires that you previously cut as described in item “B”. Take the cut end of each pickup wire and completely insert it into one of the two holes in a yellow/clear connector (UY2). Insert a 6” Red wire into the connector. With both wires completely inserted into the connector, use a pair of pliers to firmly press the yellow button of the UY2 connector so it is flush with the clear body. Strip 3/8” (9.5mm) insulation from the end of the Red wire and twist wire bundle so it is tightly bound. Optionally, use a soldering iron to lightly *tin* the end of the wire so it doesn’t unravel.
7. Use an ohmmeter to confirm continuity for each pickup coil pair (you will read some resistance). If you read an open circuit, try pressing down more firmly on each of the UY2 connectors to produce continuity. If you cannot confirm continuity, you may need to snip out the UY2 connectors and solder the wires together (making sure the solder joint is insulated to prevent shorting issues).

3. Installing the T2P-Switch

Refer to *Figure 4 – Pickguard Drill Hole Revisions* while completing these installation steps.

1. Remove the volume and tone knobs from the controls.
2. Use pliers or wrench to remove the lock nut and flat washer from both the volume and tone control.
3. Use pliers or wrench to remove the lock nut and flat washer from the input jack.

When cutting the pickup wires keeping these pickup wires as long as possible.

To modify your existing pickguard or control plate (or create a replacement) you need to remove the attached components. This will make it easy to use it as either as a template to make a replacement part, or identify where to drill the switch mounting holes.

If you are installing the T2P-Switch product into an existing (or replacement) pickguard, you need to determine two things. First, you need to confirm that there is adequate clearance for the switch product. You also need to identify the specific location to drill the switch mounting holes.

Minimum body cavity clearance dimensions for this T2P-Switch product:

0.50" wide x 1.00" long x 1.15" deep (1.27cm x 2.54cm x 2.92cm)

To determine if there is adequate perimeter clearance for the T2P-Switch product, tape the supplied **Styrofoam block** to the back side of your pickguard or control plate at the proposed position of the switches and confirm that the circuit board outside dimensions will have clearance in the body routing underneath the pickguard or control plate at the proposed position. Confirm that your routed body cavity has the 1.15” (2.92cm) depth requirements.

If you are installing a **T2P-Switch**, you should print and trim the *drill hole template*, cutting the holes out to identify their location (see Figure 4). This product uses switches that are designated as SW3 and SW5.

Once you have found the location with the needed clearance, slip the included paper *drill hole template* underneath the Styrofoam block. It will be between the pickguard and the Styrofoam block, with the printed side facing towards the back side of your pickguard. This is for a right hand instrument.

Firmly tape all 4 edges of this *drill hole template* to the back of the pickguard and remove the Styrofoam block. This identifies where the holes must be drilled to mount the PTM board. Use a center punch to *dimple* each of the centers. This will help to prevent the drill bit from “walking” when you first start drilling and result in a more precisely-drilled hole position. Before drilling, use a piece of wood stock to serve as a backing to avoid rough holes. Use an electric drill and 1/16” (1.6mm) drill bit to drill “pilot” holes at the location marked with the “+” symbol. After drilling the pilot holes (either 3 or 6) follow through with the 9/32” (7.1mm) drill bit for each of the holes. The switch mounting shafts are designed for 1/4” (6.3mm) holes, but all of the switch mounting holes must be 9/32” (7.1mm) diameter (slightly larger) to compensate for assembly variances.

Mount the T2P-Switch product using **Figure 4** as a general guide for either right-hand or left-hand use.

DO NOT REMOVE THE BACKING NUT from the switches to gain extra length if the switch threaded mounting shaft is not long enough to permit them from being mounted. Doing so will likely cause the threaded shaft of the switch to be extracted from the switch body when tightening the mounting nuts. In addition, do not excessively tighten the backup nut against the switch body because this also can cause the threaded shaft of the switch to be extracted from the switch body when tightening the backup nuts. This damage is NOT covered by our warranty.

If you are mounting the T2P-Switch product in an area with excessive thickness, it is advisable to either remove the excess thickness or cut it out a hole and fabricate a plastic cover plate in which to mount the switches.

Attach the T2P-Switch product to the pickguard. First, adjust each backing nut so when the locking nut is installed, the top surface of the locking nut will be flush with the switch shaft threads. Screw each backing nut lightly against the switch body and back off 1 complete turn to arrive at a general starting position for mounting.

Place the keyed flat washer on top of the backing nut with the locking “tang” facing towards the switch body. Discard the serrated washers as they are not used.

Insert the board’s switches through the previously drilled holes. The board will be in the orientation shown in **Figure 1** examples. Put the provided stainless steel washers over each switch and screw on the tightening nuts.

Confirm that the pickguard or control plate with the attached board will lay completely within the routed body cavity with no interference by the wood body. If it doesn't lay down flush here is what to do.

Loosen (but do not remove) all the switch mounting nuts so that the **Pickup Switch Upgrade™** board can be slightly "Shifted" to achieve the needed clearance. If that doesn't work then temporarily remove the T2P-Switch product mounting nuts. Use a rat-tail file to "elongate" the holes in the direction of the interference area. This should give you the needed clearance. If not, you will need to remove a small amount of wood from your body in the interference area to provide the needed clearance. This must be done before you can proceed.

Rewire the Volume control and Tone control as indicated in the **Figure 2** illustration presented later in this document. When reassembled, the terminals of the volume and tone controls must face away from each other.

Terminal Strip

To attach wires to the **green** terminal strip (J1) on the T2P-Switch product, use a small screwdriver or writing pen tip and press down on the square *release button* located directly above the wire hole. Hold the button down and insert the stripped wire completely into the wire connection hole and then release the button. Lightly tug on the wire to confirm it is firmly gripped by the Terminal Strip. A legend is printed on the circuit board with the name of each terminal strip wire hole from left to right. Attach each wire to the correct terminal strip hole. In all instances, connect the **GND** and **VOL** wires from the Volume/Tone control circuit displayed in **Figure 2** to the wire connection holes on the terminal strip.

T2P-Switch (with 6-hole terminal strip): [GND] [VOL] [+]NECK[-] [+]BRDG[-]

Caution: Do not insert hard items in the wire holes because it will decrease reliable electrical connection. Doing so will void your product warranty.

4. Connecting Your Wires

Refer to *Figure 7 – Final Upgrade Wiring* while completing these wire revision steps.

There is no industry standard for pickup wire lead colors. More common color pairs are red/black, red/white, black/white and white/shield. You are advised to use consistency when connecting *your* pickup wire color pairs to the [+] and [-] pickup connections on the green terminal strip (J1).

Determine which wire color for each pickup coil will be attached to the applicable [+] and [-] green terminal strip connector on our PTM board. If one of the pickup wire connections is a shielded lead, always connect the shield to a BLACK [-] wire to be inserted in the green terminal strip on our switching system.

Determine if there is enough wire length from each 2-wire pickup coil to *comfortably* reach the corresponding connectors on the green terminal strip on the **Pickup Switch Upgrade™** board. If not, refer to the “*Adding Extra Wire*” topic (page 1).

WARNING: If your pickups have a metal bottom and if either pickup coil wire is grounded to this housing (use an ohmmeter to check each wire to body), make sure your instrument’s body cavity is not lined with grounded metal shielding and the pickup housing does not have a separate grounding wire.

Reason: This will cause the pickup to “short” to ground when the pickup switch is put into the regular/reverse phase. To fix this, isolate the pickup housing from the body cavity shielding with soft foam.

Strip off 3/16” (4.7mm) insulation from the end of each pickup wire and also the input jack wires then twist the exposed wire strands so they are tightly bound. Insert the wires of each pickup pair into the correct location on the green terminal strip (J1) using the process described in the above “*Terminal Strip*” topic. Attach the wires using either of the following instructions.

Use the two gray wire nuts (71B) to connect the labeled wires to your **input jack**. The red wire goes to the hot lead (normally red) on the input jack and the black wire goes to the ground lead on the input jack.

Note: If you have a ground wire coming from the bridge (and maybe from body cavity shielding), connect them to ground lead on the input jack.

Connecting your two pickup coils to our T2P-Switch product

Connect your PB **NECK** pickup coil wire pair to the **[+]NECK [-]** connections on the green terminal strip

Connect your PB **BRIDGE** pickup coil wire pair to the **[+]BRDG [-]** connections on the green terminal strip

T2P-Switch Product Identification and Use Summary

Here is a summary of switch use for this product (see **Figure 6** for switch identification and orientation).

A complete *Switch Table* contains more details about how the switches are used for each product. It is available for download from our website's Document Library at <http://www.AweSome-Guitars.com>

SW3 is an ON-ON switch that changes the pickups from normal phase to reverse phase

SW5 is an ON-ON switch that changes the pickups from *Parallel* to *Series* connectivity

Switch Use:

SW3 puts on the **bridge** and **neck** pickup coils either in normal phase (down), or reverse phase (up).

SW5 When this switch is **down** (see Figure 6), the pickups are in a *Parallel* circuit.

When this switch is **up** it puts the **bridge** and **neck** pickups in a *Series* circuit.

Validating

Connect your instrument to an amplified source with the volume set to low. Turn the switches on and off as described in "*Switch Identification and Use Summary*" topic while gently tapping the magnet of the pickup coil that should be "on" with a small screwdriver to confirm pickup response. Also confirm the correct operation of the Volume and Tone controls.

If you receive the stated results, install the pickguard screws. Welcome to the *Grand Canyon Wide* range of AweSome pickup tones.

This product will give your P-Bass instrument a wide spectrum of four unique pickup sounds.

SWITCH COMBINATIONS USED BY T2-BOARD

| ## | SW5 | SW3 |
|----|-----|-----|
| 1. | D | D |
| 2. | D | U |
| 3. | U | D |
| 4. | U | U |

Your Description of the pickup sound

1. _____
2. _____
3. _____
4. _____

© 2011 AweSome Musical Instruments, All rights reserved worldwide
www.awesome-guitars.com

Figure 1 – Typical Stock Wiring

Here is a *typical* P-Bass stock wiring example for reference.

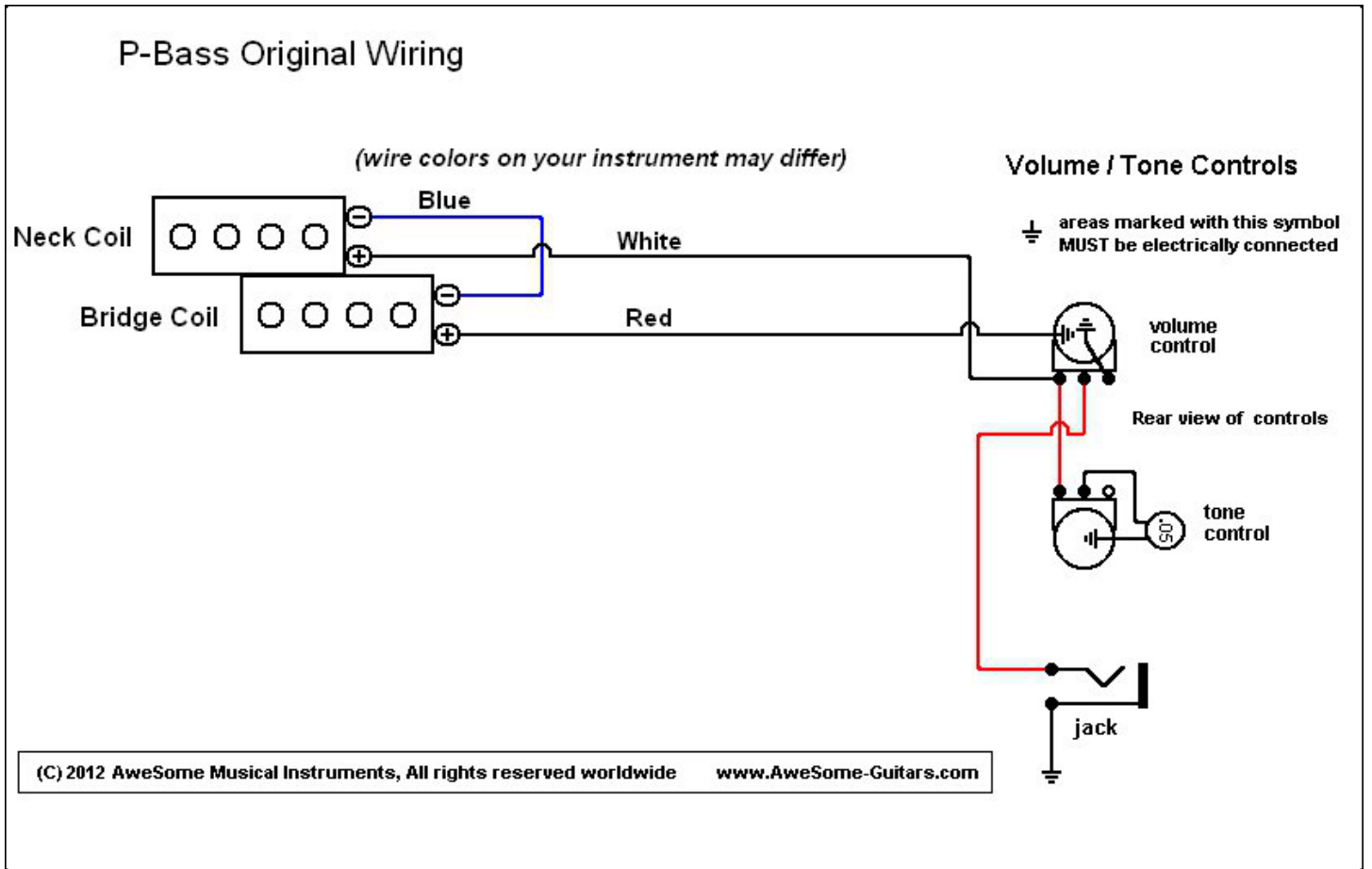
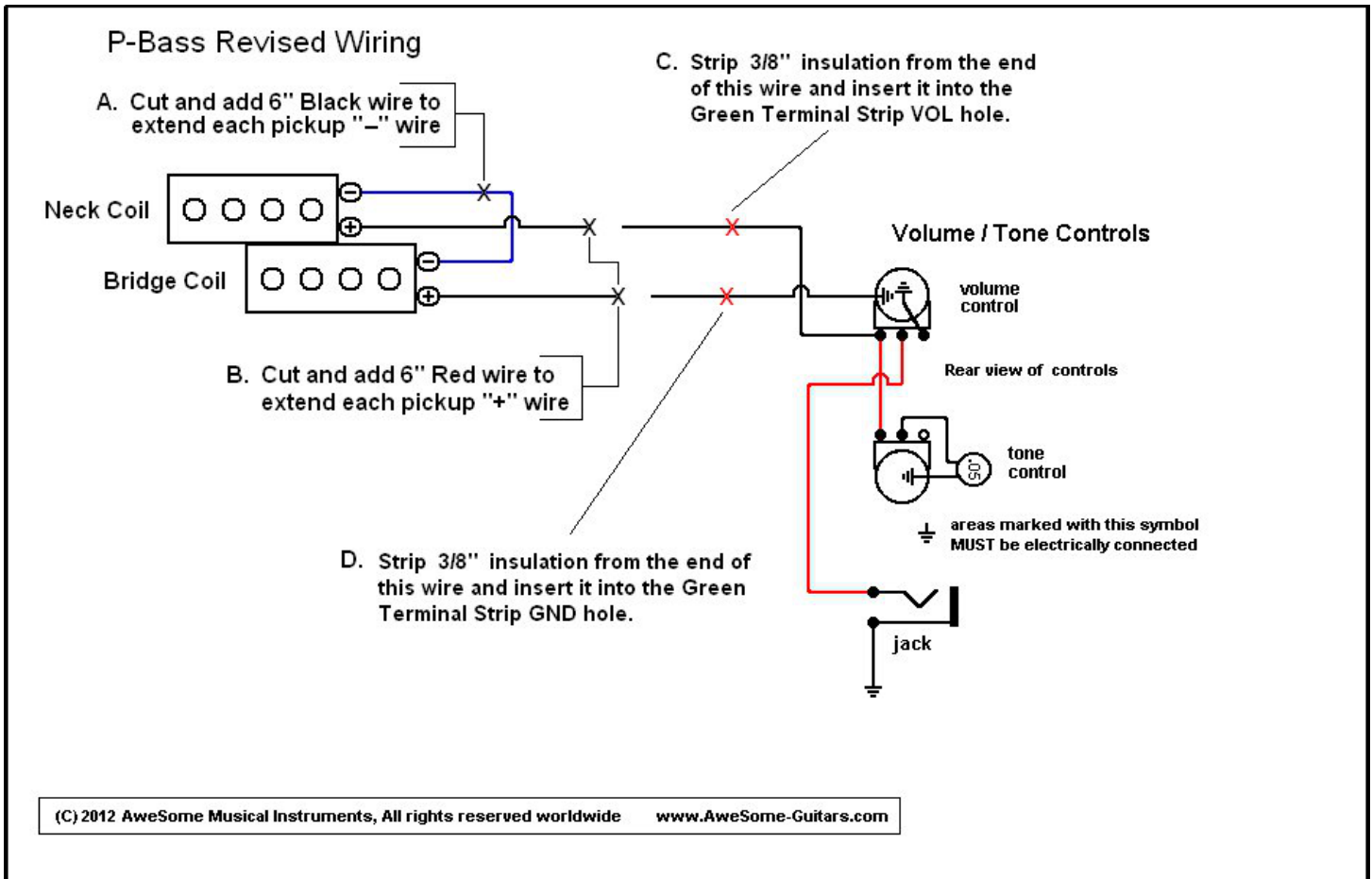

Figure 2 – Upgrade Wiring Revisions

Here are the wiring revisions you must make to install our T2P-Switch product. The wire colors in the below figure will not match the wire colors of your instrument.



(C) 2012 AweSome Musical Instruments, All rights reserved worldwide www.AweSome-Guitars.com

Figure 3 – Pickguard Drill Hole Revisions

The following figure identifies the changes you must make to the stock P-Bass pickguard. You will need to drill three holes to permit both the relocation of the Tone control slightly rearward and for the T2P-Switch product installation. The following drill hole template can be used as a guide to identify the locations of the holes. When printed, this template should accurately identify the position of the holes.

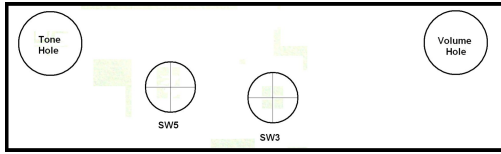

Extra Notes:

To provide the T2P-Switch mounting space needed, the Tone and Volume controls need to be oriented so the three terminals of each control are rotated and are facing away from the T2P-Switch product.

Insulating material (i.e., electrical tape, etc.) needs to be put over the green terminal strip pins (see Figure 5) to ensure the tone control body does not short against the green terminal strip pins.

Figure 4 – T2P-Switch Green Terminal Strip Designation

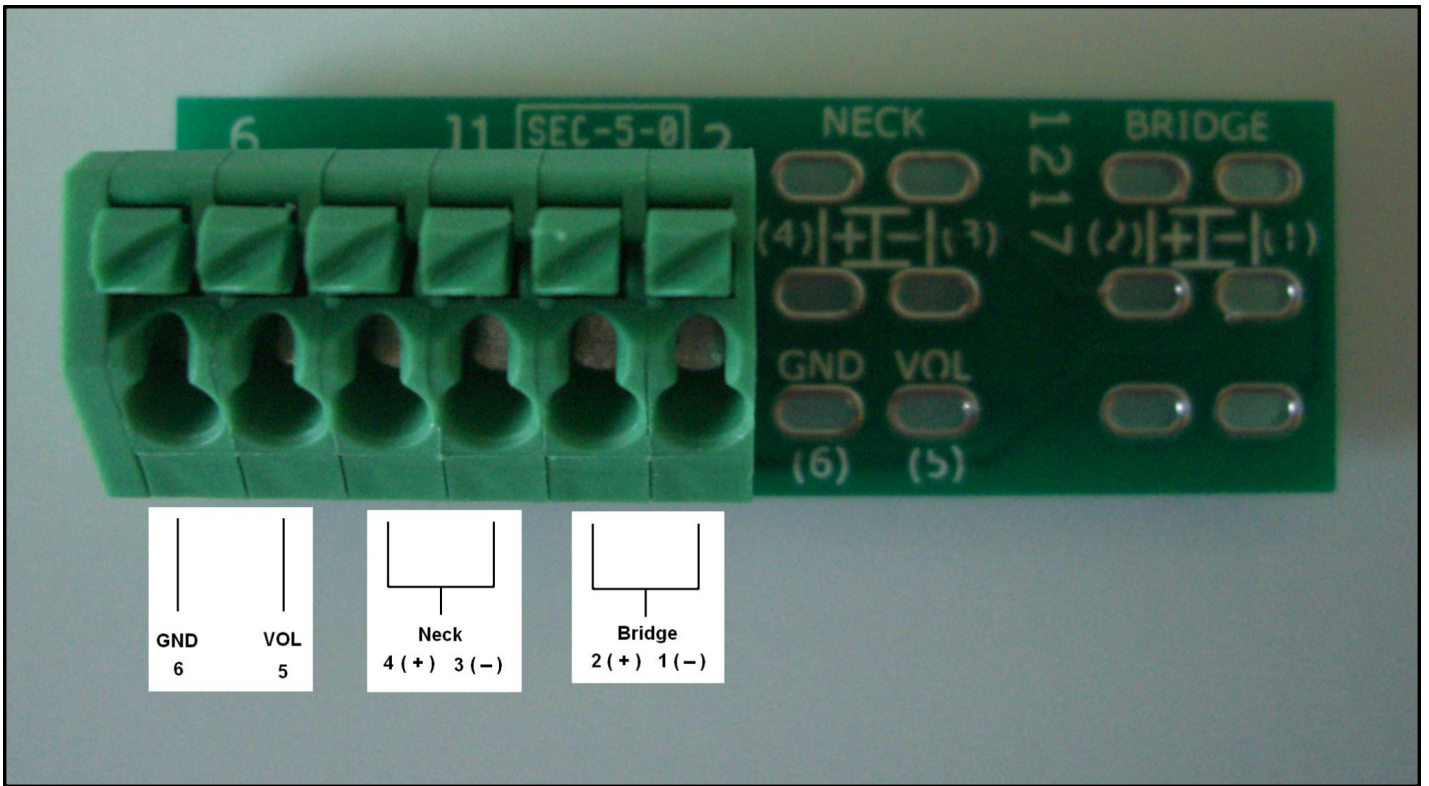

Figure 5 – T2P-Switch Orientation

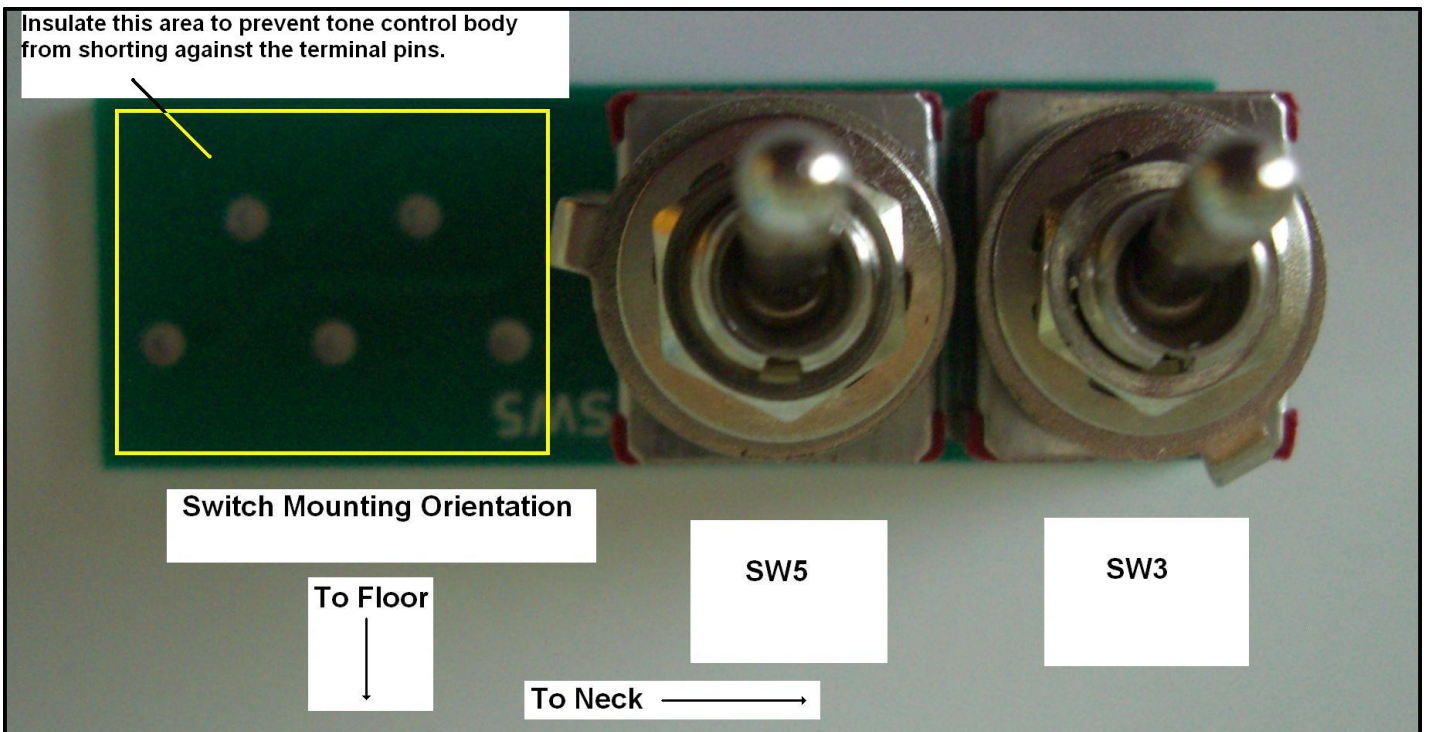
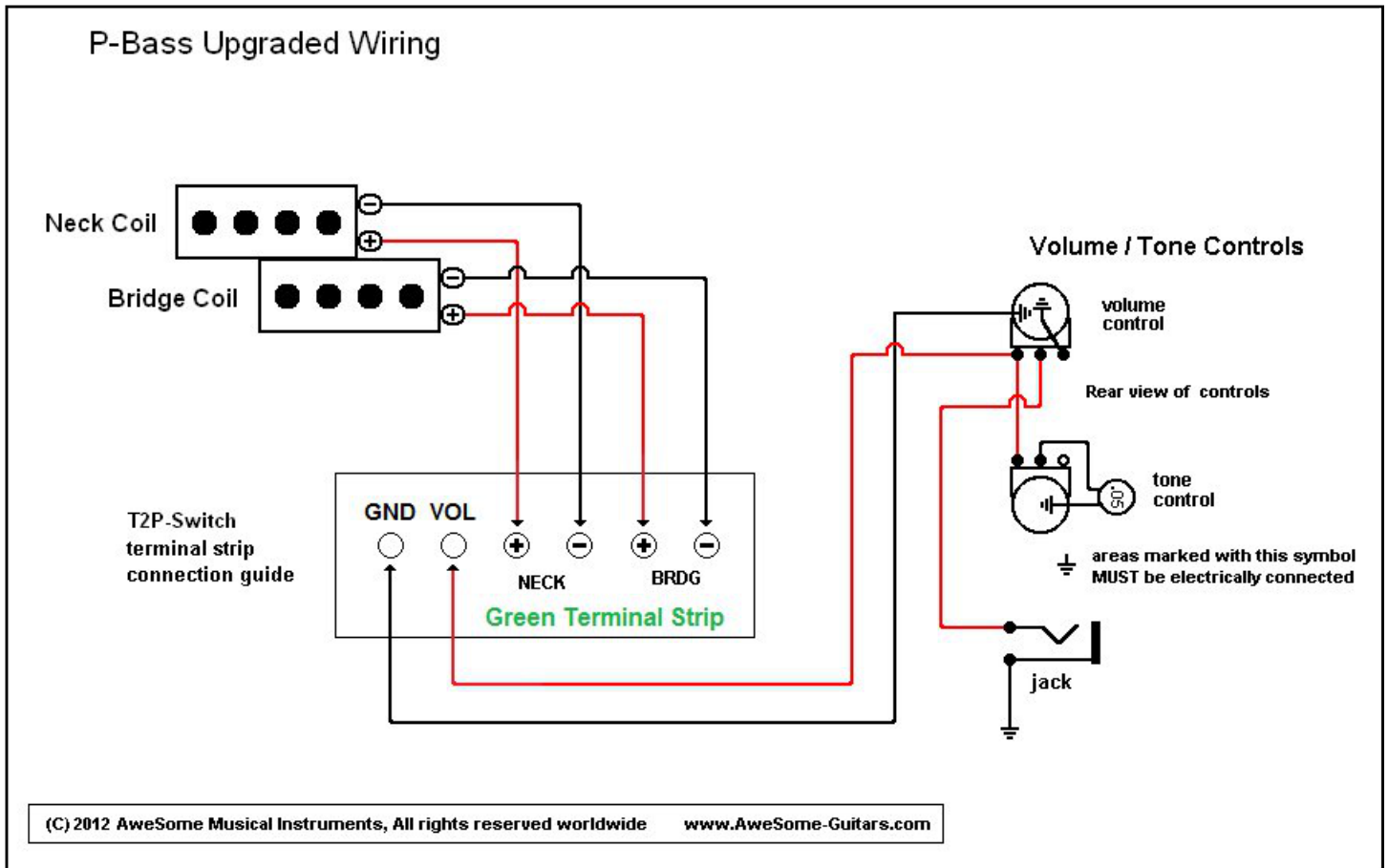

Figure 6 – Final Upgrade Wiring

This illustration shows you how everything gets wired together.



Additional Illustrations

These additional figures show how everything goes together.

Assembled but uninstalled T2P-Switch

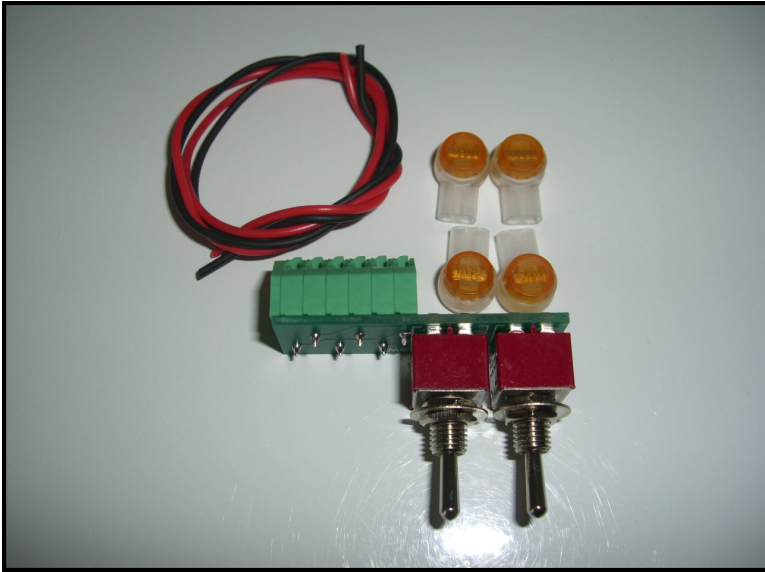

Installation Side View

Green terminal strip connections must have insulation between them and the tone potentiometer. Notice both the Volume and Tone potentiometers have their terminals facing away from the T2P-Switch product.

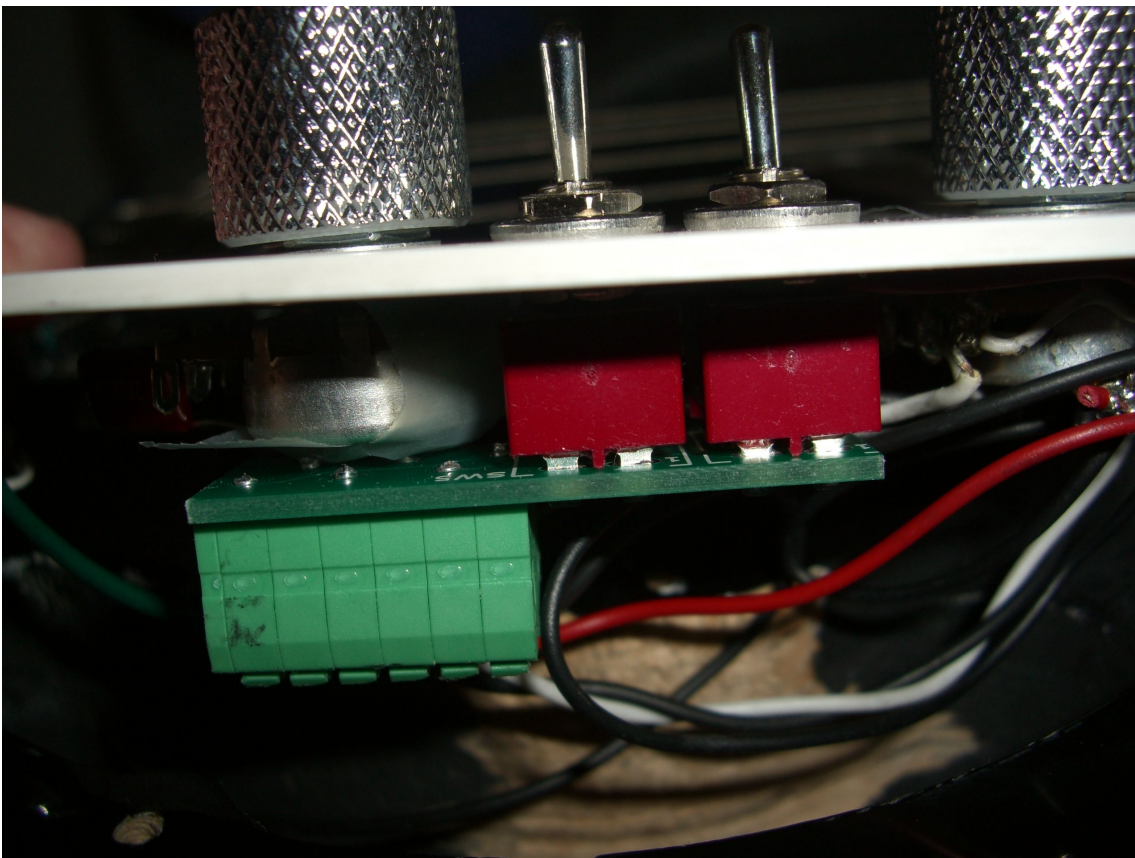

Switch Reference of Installed T2P-Switch product

