

Our T4-Switch product lets you directly control four separate pickup coils with an HH, HSS or SSSS pickup configuration to give you 68 unique pickup tones.

Our T4Plus-Switch includes an optional 6-position green terminal strip to let you use the push-pull tone pot of our **VT-3 Volume-Tone Control** to connect the switch portion of the push-pull pot to our T4Plus-Switch. This lets you put pickup coils #2 and #3 into series to give you 34 *additional* unique pickup tones. This gives you a total of **102 pickup tones** on you instrument that contains our T4Plus-Switch.

Now you can directly put all four pickup coils in series to get several incredible *jaw-dropping* **QuadraBucker™** pickup tones that are so “*Fat*”, they are... **OBESE!** Our T4Plus-Switch requires you to have either two **4-wire humbucker pickups**; one 4-wire humbucker pickup and two single-coil pickups, or four single-coil pickups.

**A. How It Works**

Using the push-pull Tone control (*see our VT-3 Volume-Tone Control product*), you can electrically put Coil-2 and Coil-3 in series. The push-pull Tone control switching function is on our T4Plus-Switch. With the Tone control shaft IN, pickup Coil-2 and Coil-3 are directly connected to the T4Plus-Switch. Pulling the Tone control shaft OUT puts Coil-2 and Coil-3 into a series circuit to give you 34 additional pickup tones.

The following pages identify how to get 102 pickup tones. **Page two** contains the wiring for our new T4Plus-Switch product. **Page three and four** describes how to use the T4Plus-Switch. **Page five** includes the additional 34 pickup tone map switch positions (*see Document #E for the tone map for the first 68 pickup tones*). **Page six** has important information about 4-wire humbucker pickups. Our website Document Library (*see document #F and #G*) has worksheets that let you map all of the pickup tones.

Shown below is the two terminal strips of our T4Plus-Switch. The 10-position terminal strip is used to connect your pickup wires and the VOL/GND wires on our VT-3 Volume-Tone control. The 6-position terminal strip is used to connect the 4 marked wires of the VT-3 push-pull tone pot switch.

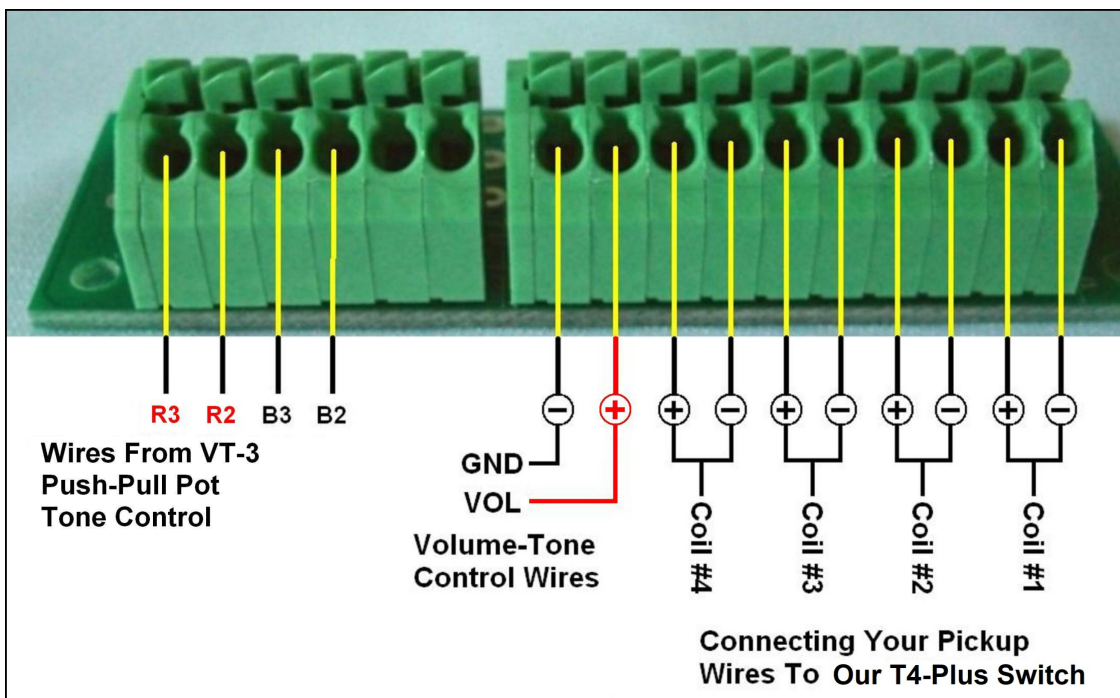

# T4Plus-Switch Wiring – Using Our VT-3 Volume-Tone Control.

How the push-pull pot wires are connected to the T4Plus-Switch to produce **QuadraBucker™** pickup tones.

Using our **T4 Pickup Switch Upgrade™** product with 1 push-pull pot to get a lot more pickup tones. We are the only company that lets you put all four pickup coils in series to create **QuadraBucker™** pickup tones

These connections are used with our T4-Switch (E1 version) printed circuit board.

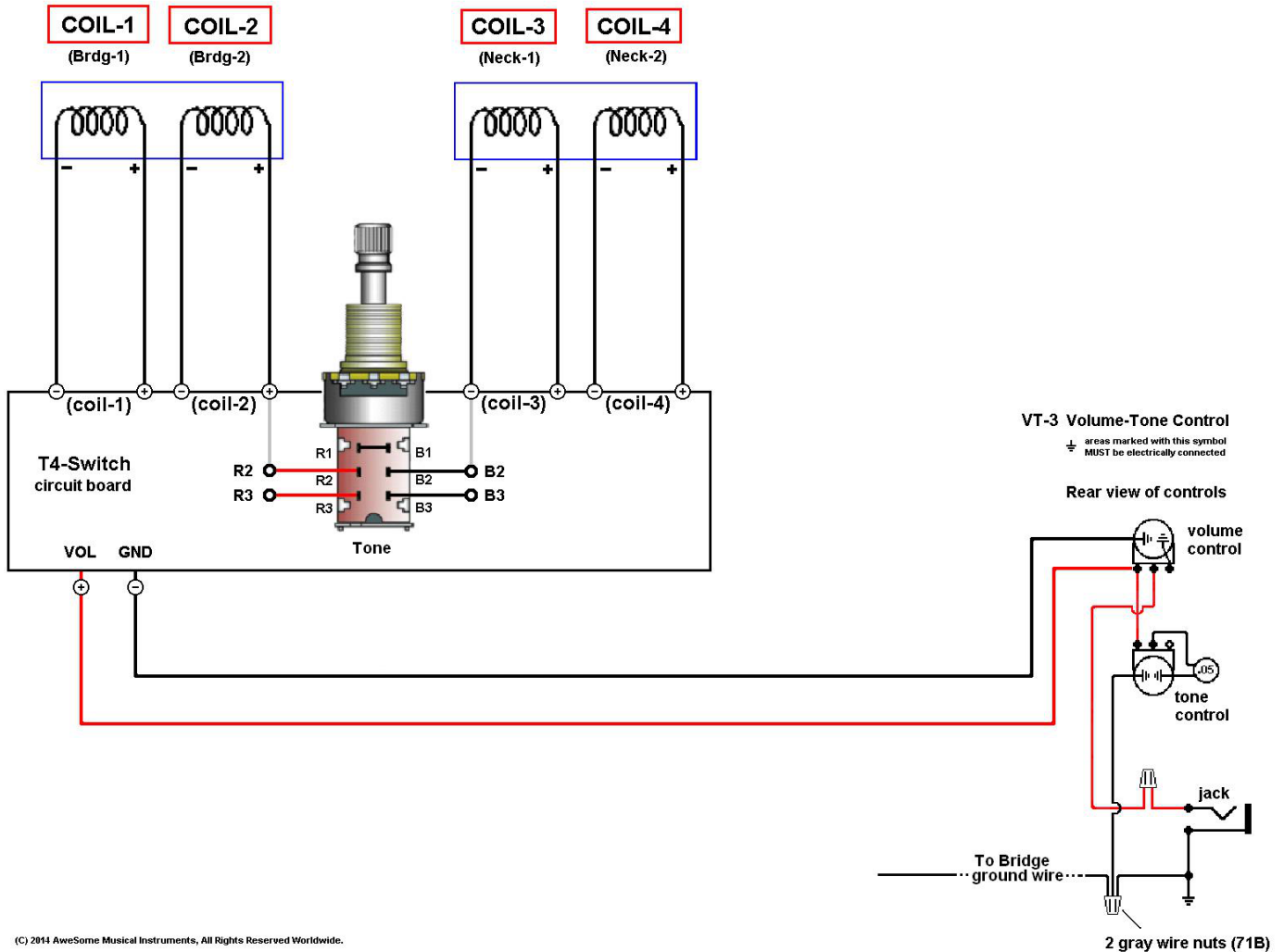

## B. HOW YOU USE THE T4PLUS-SWITCH

Here are how the switches of the T4Plus-Switch product are mounted and laid out from instrument rear to front:

(rear) SW1 S5B SW2 SW3 S5N SW4 (front)

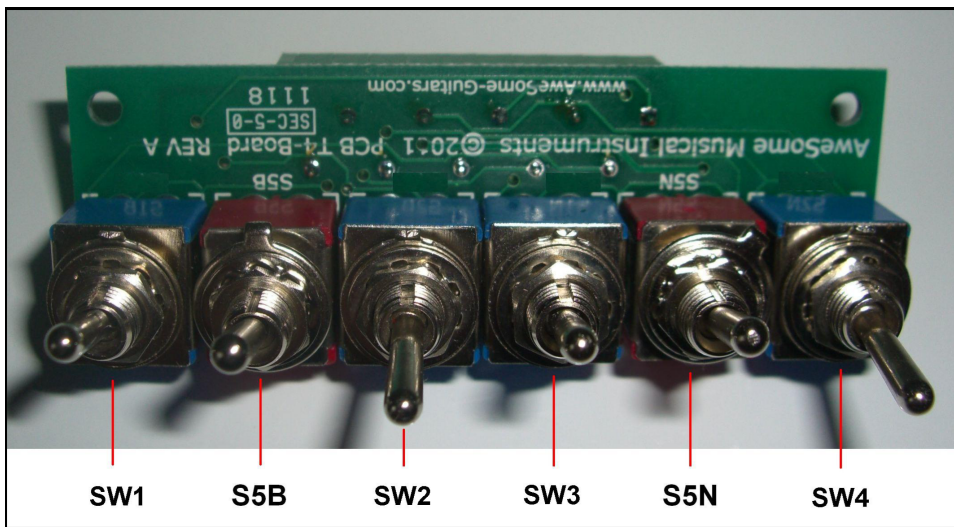

There are really two "groups" of switches: (SW1, S5B, SW2) -and- (SW3, S5N, SW4)

### Here is how the switches are used:

Switches SW1, SW2, SW3 and SW4 are ON-OFF-ON switches used to turn an individual pickup coil Off and On. The middle position of each switch is Off. The down position turns the pickup On (in *normal-phase*) and the Up position turns the pickup On (in *reverse-phase*).

Switches S5B and S5N are ON-ON (a.k.a. ON-NONE-ON) switches that are used to put select pickup coils into a **Series circuit** when in the Up position. When Down, the select pickup coils are in a **Parallel circuit**. Pretty simple, don't you agree?

When switches S5B and S5N are in the Down position, you will get 29 different pickup tones from the various combinations of four pickup coils being Off or On (either in *normal-phase* or in *reverse-phase*) using switches SW1, SW2, SW3 and SW4. These pickup tones are also due to the combination of pickup coils being in a **Parallel circuit**.

The other switches (S5B and S5N) are ON-ON (a.k.a. ON-NONE-ON) switches are used to put select pickup coils into a **Series circuit**. Here are two things you must remember when putting pickup coils into a Series circuit:

First, putting two pickup coils in Series circuit creates a "*Compound*" (i.e., Humbucker) pickup that gives you about 8 to 15 percent More output (think Heavy Metal/Jazz tone).

Second, because the pickup coils are in a Series circuit, **BOTH** of the affected pickup coils that are in a Series circuit **MUST** be On (either in *normal-phase* or *reverse-phase*). Any non-Series circuit pickup can be either Off or On (either in *normal-phase* or *reverse-phase*).

## What Each Switch Controls

Typically, for an instrument with two 4-wire humbucker pickups, pickup coil #1 is the bridge south coil, coil #2 is the bridge north coil. Pickup coil #3 is the neck south coil, while pickup coil #4 is the neck north coil.

If your instrument has one 4-wire humbucker pickup and two single-coil pickups (where the humbucker is in the bridge position), pickup coil #1 is the bridge south coil, coil #2 is the bridge north coil. Pickup coil #3 is the middle coil, while pickup coil #4 is the neck coil.

Switch SW1: Turns on pickup coil #1 (down is *normal-phase*, up is *reverse-phase*, center is Off.)

Switch S5B: Puts both coil #1 and coil #2 into a Series circuit when Up. Both pickup coils MUST be On.

Switch SW2: Turns on pickup coil #2 (down is *normal-phase*, up is *reverse-phase*, center is Off.)

Switch SW3: Turns on pickup coil #3 (down is *normal-phase*, up is *reverse-phase*, center is Off.)

Switch S5N: Puts both coil #3 and coil #4 into a Series circuit when Up. Both pickup coils MUST be On.

Switch SW4: Turns on pickup coil #4 (down is *normal-phase*, up is *reverse-phase*, center is Off.)

This added capability lets you enhance your existing “*palette*” of pure analog *pickup tones* with incredible pickup tones that are so *fat*, they’re **obese**. These are amazing pickup tones that let you put three coils in series to produce several **TroikaBucker™** pickup tones (labeled “**T**”). You can also put all four pickup coils in series to produce several **QuadraBucker™** pickup tones (labeled “**Q**”) – incredible and unique pickup tones that are unavailable on other instruments.

### C. Switch Table For The Added Tones

This Switch Table shows the *additional* pickup tone combinations (*beyond the T4 Switch*) using our VT-3 Volume-Tone Control with our T4Plus-Switch. See our Document Library for the first 68 pickup tone combinations. See our document library for all 102 pickup tone combinations.

##	NECK Control			Tone Pot shaft is	BRDG Control			Your Description Of The Pickup Tone
	Coil4 SW4	Coil3 S5N SW3	Coil2 SW2		S5B	Coil1 SW1		
69.		D		OUT	D			69. _____
70.		U		OUT	D			70. _____
71.	D		D	OUT	D			71. _____
72.	U		D	OUT	D			72. _____
73.	D	U	D	OUT	D			73. T _____
74.	U	U	D	OUT	D			74. T _____
75.	D		D	OUT	U			75. _____
76.	U		D	OUT	U			76. _____
77.	D	U	D	OUT	U			77. T _____
78.	U	U	D	OUT	U			78. T _____
79.			D	OUT	D		D	79. _____
80.			U	OUT	D		D	80. _____
81.	D		D	OUT	D		D	81. _____
82.	U		D	OUT	D		D	82. _____
83.	D	U	D	OUT	D		D	83. _____
84.	U	U	D	OUT	D		D	84. _____
85.			D	OUT	U		D	85. _____
86.			U	OUT	U		D	86. _____
87.	D		D	OUT	U		D	87. _____
88.	U		D	OUT	U		D	88. _____
89.	D	U	D	OUT	U		D	89. _____
90.	U	U	D	OUT	U		D	90. _____
91.			D	OUT	D	U	D	91. _____
92.			U	OUT	D	U	D	92. _____
93.	D		D	OUT	D	U	D	93. _____
94.	U		D	OUT	D	U	D	94. _____
95.	D	U	D	OUT	D	U	D	95. Q _____
96.	U	U	D	OUT	D	U	D	96. Q _____
97.			D	OUT	U	U	D	97. T _____
98.			U	OUT	U	U	D	98. T _____
99.	D		D	OUT	U	U	D	99. _____
100.	U		D	OUT	U	U	D	100. _____
101.	D	U	D	OUT	U	U	D	101. Q _____
102.	U	U	D	OUT	U	U	D	102. Q _____

Q = QuadraBucker pickup tone  
(all four coils in series)  
T = TroikaBucker pickup tone  
(three coils in series)

## IMPORTANT Notes About 4-Wire Humbucker Pickups

Most 4-wire humbucker pickups are made to be *Symmetrical*. This means that the two coils of the humbucker pickup package are identical (*i.e., same impedance/resistance*). Although not necessarily bad in itself, when each of the two coils are separately controlled the lack of versatility and performance becomes clear. Turn on one of the coils by itself and get a pickup tone. Separately turn on the other coil by itself and get the exact same pickup tone. This design is an obstacle that prevents you from enjoying maximum pickup tone versatility.

When we introduced our T4-Switch in 2011, it became clear that this redundant tone from each separate identical coil of the *Symmetrical* 4-wire humbucker pickup was disappointing because it severely limited the true benefit and pickup tone versatility that our new T4-Switch product was capable of providing.

We fixed this *Symmetrical* 4-wire humbucker pickup shortcoming by creating our AweSome *Asymmetrical* 4-wire humbucker pickups that would give you access to a Grand Canyon Wide range of unique pickup tones.

We had to design the specifications for the *Asymmetrical* 4-wire humbucker pickups from scratch. Further, the characteristics of the Bridge pickup needed to be different than that of the Neck pickup. Each of the two coils of the newly designed *Asymmetrical* 4-wire humbucker pickup set have a *differential* of about 15 percent. This means that each coil when separately turned on will produce a noticeably different pickup tone.

We *also* wanted the Bridge and Neck pickups to have completely different impedance/magnet characteristics to maximize pickup tone versatility with the *combinations* of these four dissimilar pickup coils.

We spent several months creating two pairs of truly versatile *Asymmetrical* 4-wire humbucker pickups that harnessed the incredible versatility of our T4-Switch product and produced the maximum in tone versatility.

The result of this effort is our new true "*golden mean*" of *Asymmetrical* 4-wire humbucker pickups.

If your HSS or HH instrument has *Symmetrical* 4-wire humbucker pickups and you want to use our T4-Switch or T4Plus-Switch product, consider replacing them with our new *Asymmetrical* 4-wire humbucker pickups that are designed to be used with our AweSome T4-Switch and T4Plus-Switch.

Visit our website's (<http://www.AweSome-Guitars.com>) *Document Library* for more useful wiring tips.

We have an extensive product catalog of upgrade products to help you *transform your dreams into reality*.